



TOWN COUNCIL WORK SESSION & MEETING
Zoom Webinar and/or Town Council Chamber
3 S. Timber Ridge Parkway, Severance, CO 80550

AGENDA
TOWN COUNCIL WORK SESSION & MEETING
Tuesday, April 28, 2026, at 5:00 PM

A. CALL TO ORDER WORK SESSION (5:00 PM)

The Goal of the Work Session is to have the Town Council receive information on topics of Town business from the Town Manager, Town Attorney and Town Staff in order to exchange ideas and opinions regarding these topics.

1. Pg. 4 - Council Member Petition Policy

B. CALL TO ORDER REGULAR MEETING (6:00 PM)

1. Roll Call

2. Pledge of Allegiance

3. Proclamation

a. Pg. 6 - Mental Health Month

b. Pg. 7 - National Police Week

c. Pg. 8 - Professional Municipal Clerks Week

d. Pg. 9 - Small Business Week

4. Pg. 10 - Arbor Day Winners

5. Agenda Review by Town Manager

6. Consent Calendar

The Consent Calendar is intended to allow the Town Council to spend time and energy on the important items and not routine actions. A Council Member may request an item on this calendar to be "pulled" off the Consent Calendar and considered separately as a regular agenda item. Items remaining on the Consent Calendar will be approved by Town Council with one vote.

a. Pg. 11 - Town Council Meeting Minutes 4.14.26

b. Pg. 15 - March 2026 Financial Statements

c. Pg. 56 - March 2026 Payables

7. Approval of Agenda

8. Public Comment

The purpose of the Public Comment is for members of the public to speak to the Town Council on any subject not scheduled on the agenda. To accomplish scheduled agenda items, comments should be limited to three minutes for those attending in person or an appropriate time as deemed by the Mayor. The Town Council is not obligated to make decisions or take action on comments but may choose to schedule the matter for a later discussion. Those addressing the Town Council, please state your name and address and sign-in.

9. Council Member Comments

10. Reports

Council approval may be sought for administrative actions in association with staff reports.

- a. Town Attorney
- b. Town Staff
- c. Town Management
- d. Council Members Liaisons
- e. Mayor

C. TOWN COUNCIL

1. Pg. 98 - Clearview Library Presentation

- Discussion
- Staff Presentation: Nicholas Wharton, Town Manager

2. Pg. 104 - Resolution 2026-06R: A Resolution of the Town Council of the Town of Severance, Colorado, approving an Intergovernmental Agreement between the Town of Severance, Colorado, and the City of Thornton, Colorado, for an Emergency Raw Water Interconnection

- Legislative
- Staff Presentation: Shani Porter, Planning Director

D. COUNCIL MEMBER PETITIONS

Council Members may ask for items to be added to future agendas.

E. ADJOURN

F. EXECUTIVE SESSION

- 1. Considering the purchase, acquisition, lease, transfer, or sale of any real, personal, or other property interest, pursuant to §24-6-402(4)(a), C.R.S., with regard to certain property in downtown Severance.**
- 2. Concerning the purchase, acquisition, lease, transfer, or sale of any real, personal, or other property interest, pursuant to C.R.S. §24-6-402(4)(a), and for the purpose of determining positions relative to matters that may be subject to negotiations; developing a strategy for negotiations; and instructing negotiators, pursuant to C.R.S. §24-6-402(4)(e)(I), and conferences with Town Attorney for the purposes of receiving legal advice on specific legal questions, pursuant to C.R.S. §26-6-402(4)(b),**

with regard to the Wastewater Treatment Service Agreement with the Town of Windsor

Town Council Meeting

Tuesday, April 28, 2026, 5:00 PM (MDT)

The Town Council reserves the right to adjourn to a virtual-only meeting at its discretion should the need arise.

Registration URL

<https://us02web.zoom.us/j/89354721574?pwd=2TJORo1yOgUN5NB28octprdXWugaLI.1>

The Town of Severance does not discriminate on the basis of race, color, national origin, sex, religion, age or disability in the provision of services. For disabled persons needing reasonable accommodation to attend or participate in a town service, program, public meeting, or activity, call 970-686-1218 at least 72 hours in advance. Disabled access is available from the front entrance of the Town Hall.



AGENDA ITEM SUMMARY

AGENDA ITEM	SUBMITTED BY	PRESENTED BY
Pg. 4 - Council Member Petition Policy	Brittany Vandermark, Mayor Pro-tem	Mayor Pro-Tem Vandermark
ACTION REQUESTED		
To discuss solutions on how we can better communicate information on agenda/petition items to the Citizen Advisory Board (CAB).		<u>Discussion</u>
BRIEF HISTORY OF ITEM		
<p>CAB is looking to have more details on petitions. When meeting with CAB, the board discussed that the following information is included in their packets so they can come prepared with ideas and thoughts:</p> <ul style="list-style-type: none"> • Financial impact • Relation to Comprehensive Plan • Summary of petition • History of petition • Clarity if Council is looking for feedback or recommendations from CAB • How it fits in the Values and Mission. <p>This makes the whole process more transparent for CAB and for the community members.</p>		
BRIEF SUMMARY		
<p>During our joint work session with the Citizen Advisory Board (CAB), CAB requested more details on Town Council petitions. This was then taken to CAB as a petition by Mayor Pro-Tem Vandermark, and discussed with feedback being presented to the Town Council.</p>		
PUBLIC SUPPORT/CONCERN		
<p>CAB supports this coming to Council as a Work Session item unanimously.</p>		
ANALYSIS AND RECOMMENDATION		
<p>Mayor Pro-Tem Vandermark is recommending that an Action Item Summary (AIS) is filled out for all petitions going to CAB.</p>		
MATERIALS SUBMITTED		
<p>The following materials were submitted and included in this packet:</p> <ol style="list-style-type: none"> 1. Agenda Item Summary (Blank) 		



AGENDA ITEM SUMMARY

AGENDA ITEM	SUBMITTED BY	PRESENTED BY
ACTION REQUESTED		
BRIEF HISTORY OF ITEM		
BRIEF SUMMARY		
PUBLIC SUPPORT/CONCERN		
ANALYSIS AND RECOMMENDATION		
MATERIALS SUBMITTED		



**MENTAL HEALTH MONTH
MAY 2026**

WHEREAS, mental health is just as important as physical health, and taking care of our minds helps ourselves and our families, schools, and workplaces thrive; and

WHEREAS, More than one in five adults in the United States faces a mental health challenge each year, and many people in our community are living with stress, anxiety, depression, trauma, substance use, and other mental health conditions; and

WHEREAS, getting help early and having access to affordable behavioral healthcare can prevent crises, reduce suicides, lower hospital stays, and prevent incarceration, leading to healthier residents of Severance; and

WHEREAS, residents of Severance have access to compassionate, comprehensive services, including counseling, crisis response, residential care, and community-based supports through North Range Behavioral Health; and

WHEREAS, North Range Behavioral Health has achieved federal CCBHC Certified Community Behavioral Health Clinic designation and is a Comprehensive and Essential mental health Safety Net Provider serving Weld County, and;

WHEREAS, North Range Behavioral Health works with schools, medical providers, first responders, health and human services, employers, faith communities, and local partners to make sure mental health support is available when people need it; and

WHEREAS, National Mental Health Month is observed each May to raise awareness, reduce stigma, support recovery, and remind people that it is okay to ask for help.

NOW, THEREFORE, we, the Town Council of Severance, do hereby proclaim May as

MENTAL HEALTH MONTH

in Severance and encourage the residents, businesses, schools, government agencies, and community groups, to recommit to support mental health awareness, promote understanding, and help ensure that mental health care is available to everyone who needs it.

IN WITNESS WHERE OF, I have hereto set my hand and caused the seal of the Town of Severance, Colorado to be affixed this ____ day of _____, 2026.

[Seal]

Matthew Fries, Mayor



**NATIONAL POLICE WEEK
MAY 10 - 16, 2026**

WHEREAS, in 1962 the U.S. Congress proclaimed May 15th as National Peace Officers Memorial Day and the week in which May 15th occurs as National Police Week for the purpose of honoring American Law Enforcement Officers who have lost their lives in the line of duty for the safety and protection of others; and

WHEREAS, this year, May 10 - May 16, 2026, will be National Police Week; and

WHEREAS, federal statute directs that all flags be flown at half-staff on May 15th in honor of fallen officers and their families; and

WHEREAS, 24,775 names of Officers killed in the line of duty have been inscribed on the National Law Enforcement Officers Memorial in Washington, DC, dating back to the first known death in 1786; and

WHEREAS, dating back to 1862, there have been 365 law enforcement Officers killed in the line of duty in Colorado; and

WHEREAS, the Town of Severance wishes to honor all American Law Enforcement Officers who have made the supreme sacrifice; and

WHEREAS, the members of the Severance Police Department play an essential role in safeguarding the rights and freedoms of the citizens of the Town of Severance; and

NOW, THEREFORE, I, Matthew Fries, by virtue of the authority vested in me as Mayor of the Town of Severance, Colorado, do hereby proclaim May 10 - 16, 2026, as National Police Week in the Town of Severance and publicly salute the service of the Law Enforcement Officers of Severance and other communities.

IN WITNESS WHEREOF, I have hereto set my hand and caused the seal of the Town of Severance, Colorado to be affixed this 28th day of April 2026.

[Seal]

Matthew Fries, Mayor



**PROFESSIONAL MUNICIPAL CLERKS WEEK
MAY 3rd – 9th, 2026**

WHEREAS, The Office of the Professional Municipal Clerk, a time honored and vital part of local government exists throughout the world, and

WHEREAS, The Office of the Professional Municipal Clerk is the oldest among public servants, and

WHEREAS, The Office of the Professional Municipal Clerk provides the professional link between the citizens, the local governing bodies and agencies of government at other levels, and

WHEREAS, Professional Municipal Clerks have pledged to be ever mindful of their neutrality and impartiality, rendering equal service to all.

WHEREAS, The Professional Municipal Clerk serves as the information center on functions of local government and community.

WHEREAS, Professional Municipal Clerks continually strive to improve the administration of the affairs of the Office of the Professional Municipal Clerk through participation in education programs, seminars, workshops and the annual meetings of their state, provincial, county and international professional organizations.

WHEREAS, It is most appropriate that we recognize the accomplishments of the Office of the Professional Municipal Clerk.

NOW, THEREFORE, we, the Town Council of Severance, do hereby proclaim May 3rd - 9th, 2026 as

Professional Municipal Clerks Week

In Severance and call upon the citizens, government agencies, public and private institutions, businesses, and schools to commit to extending appreciation to our Professional Municipal Clerk, Ms. Sarah Jacobsen and to all Professional Municipal Clerks for the vital services they perform and their exemplary dedication to the communities they represent.

IN WITNESS WHERE OF, I have hereto set my hand and caused the seal of the Town of Severance, Colorado to be affixed this 28th day of April, 2026.

[Seal]

Matthew Fries, Mayor



**SMALL BUSINESS WEEK
MAY 3 – 9, 2026**

WHEREAS, America’s progress has been driven by pioneers who think big, take risks, and work hard; and

WHEREAS, from in-home-based business and storefront shops that anchor local streets to the storefront shops that anchor local streets to the high-tech startups that keep America on the cutting edge, businesses are the lifesavers of our economy and the cornerstones of our nation’s promise; and

WHEREAS, small business owners have energy and a passion for what they do; and

WHEREAS, when we support small businesses, jobs are created, and local communities preserve their unique culture; and

WHEREAS, because this country has more than 36 million small businesses that employ 59 million people in our economy, we cannot resolve to create jobs and spur economic growth in America without discussing ways to support our entrepreneurs; and

WHEREAS, Severance, Colorado supports and joins in the National Small Business Week effort happening May 3 – May 9, 2026, to help America’s small businesses do what they do best, create jobs, and ensure that our communities remain as vibrant tomorrow as they are today;

NOW, THEREFORE, the Town Council of the Town of Severance, State of Colorado, do hereby proclaim May 3 – 10, 2026, as Severance Small Business Week, and upon the people of Severance to recognize the unique character and success small businesses bring to our community.

IN WITNESS WHERE OF, I have hereto set my hand and caused the seal of the Town of Severance, Colorado to be affixed 28th day of April, 2026.

[Seal]

Matthew Fries, Mayor



AGENDA ITEM SUMMARY

AGENDA ITEM	SUBMITTED BY	PRESENTED BY
Pg. 10 - Arbor Day Winners	Nicholas Wharton, Town Manager	Mayor Fries
ACTION REQUESTED		
This is a presentation from the Range View Elementary School winners.	<u>Presentation</u>	
BRIEF HISTORY OF ITEM		
BRIEF SUMMARY		
<p>Range View Elementary held a drawing contest in celebration of Arbor Day. The students were asked to draw a picture with the following theme: "Save the trees: Why are trees important to humans and animals"</p> <p>The winners of the contest were selected: Grades Kindergarten - 2nd: 1st- Dulce M 2nd – Lilly P 3rd- Delany M</p> <p>Grades 3rd - 5th: 1st- Landon S 2nd- Owen S 3rd- Atly B</p>		
PUBLIC SUPPORT/CONCERN		
None at this time.		
ANALYSIS AND RECOMMENDATION		
MATERIALS SUBMITTED		
The following materials were submitted and included in this packet: None		



TOWN COUNCIL WORK SESSION & MEETING
Zoom Webinar and/or Town Council Chamber
3 S. Timber Ridge Parkway, Severance, CO 80550

WORK SESSION & MEETING MINUTES
Tuesday, April 14, 2026, at 5:00 PM

Mayor: Matthew Fries
Mayor Pro-tem: Brittany Vandermark
Council Members: David Bruen
Craig Joseph
Stephen Gagliardi
Karen Hessler
Josh Ochs
Audience: Josh Olhava Ayres Director of Planning & Economic
Development, Lindsey Wilson Ayres Community Planner
Staff: Nicholas Wharton, Town Manager
Lindsay Radcliff-Coombes, Deputy Town Manager
Sarah Jacobsen, Town Clerk
Shani Porter, Planning Director
Ken Chavez, Police Chief
Andrew Rogers, Town Attorney

A. CALL TO ORDER WORK SESSION (5:00 PM)

The Goal of the Work Session is to have the Town Council receive information on topics of Town business from the Town Manager, Town Attorney and Town Staff in order to exchange ideas and opinions regarding these topics.

1. Pg. 4 - Great Western Railway Rehab Discussion

- Discussion
- Staff Presentation: Stephen Gagliardi, Council Member
This item was discussed second on the agenda. Councilmember Gagliardi spoke to the Town Council about the Great Western Railway Engine and Caboose rehab estimated costs.

2. Pg. 5 - Downtown Project Discussion

- Discussion
- Staff Presentation: Nicholas Wharton, Town Manager
This item was discussed first on the agenda. A presentation was given by the Town Manager, Nicholas Wharton, on the revitalization options for the Severance downtown area, the northeast block of 4th and CR23.

B. CALL TO ORDER REGULAR MEETING (6:00 PM)

1. Roll Call

2. Pledge of Allegiance

3. Pg. 10 - Proclamation: Arbor Day April 24, 2026

4. Agenda Review by Town Manager

5. Consent Calendar

The Consent Calendar is intended to allow the Town Council to spend time and energy on the important items and not routine actions. A Council Member may request an item on this calendar to be "pulled" off the Consent Calendar and considered separately as a regular agenda item. Items remaining on the Consent Calendar will be approved by Town Council with one vote.

MOTION WAS MADE BY Mayor Pro-tem Vandermark, seconded by Council Member Gagliardi to Approve Consent Calendar. All Council Members present voting Yes.

MOTION PASSED

a. Pg. 11 - Town Council Meeting Minutes 3.24.26

6. Approval of Agenda

MOTION WAS MADE BY Mayor Pro-tem Vandermark, seconded by Council Member Ochs to Approve the Agenda. All Council Members present voting Yes.

MOTION PASSED

7. Public Comment

The purpose of the Public Comment is for members of the public to speak to the Town Council on any subject not scheduled on the agenda. To accomplish scheduled agenda items, comments should be limited to three minutes for those attending in person or an appropriate time as deemed by the Mayor. The Town Council is not obligated to make decisions or take action on comments but may choose to schedule the matter for a later discussion. Those addressing the Town Council, please state your name and address and sign-in.

No public comment.

8. Council Member Comments

9. Reports

Council approval may be sought for administrative actions in association with staff reports.

- a. Town Attorney
- b. Town Staff
- c. Town Management
- d. Council Members Liaisons
- e. Mayor

C. TOWN COUNCIL

1. Pg. 15 - Planning Commissioner Appointment

- Legislative, Discussion
- Staff Presentation: Shani Porter, Planning Director
The Town Council interviewed and selected Michael Hall to fill the Planning Commissioner seat for a term through June 2027.

MOTION WAS MADE BY Mayor Pro-tem Vandermark, seconded by Council Member Gagliardi to appoint the Planning Commissioner as Michael Hall. All Council Members present voting Yes.

MOTION PASSED

2. Pg. 24 - Resolution 2026-12R: A Resolution of the Town Council of the Town of Severance, Colorado, amending the Code of Conduct and Ethics in accordance with section 3.06 of the Home Rule Charter

- Legislative
- Staff Presentation: Andrew Rogers, Town Attorney

MOTION WAS MADE BY Mayor Pro-tem Vandermark, seconded by Council Member Ochs to Approve Resolution 2026-12R: A Resolution of the Town Council of the Town of Severance, Colorado, amending the Code of Conduct and Ethics in accordance with section 3.06 of the Home Rule Charter with an amendment to section 10 L to include reasonable attorney fees.. All Council Members present voting Yes.

MOTION PASSED

3. Pg. 63 - Ordinance 2026-03: An Ordinance of the Town Council of the Town of Severance, Colorado, repealing and reenacting section 6-1-150 of the Severance Municipal Code regarding Solicitors, Door-to-Door Salespersons

- Legislative, Public Comment
- Staff Presentation: Andrew Rogers, Town Attorney
Public comment opened at 7:21 p.m. No one wished to comment.

MOTION WAS MADE BY Council Member Bruen, seconded by Council Member Hessler to Adopt Ordinance 2026-03: An Ordinance of the Town Council of the Town of Severance, Colorado, repealing and reenacting section 6-1-150 of the Severance Municipal Code regarding Solicitors, Door-to-Door Salespersons. All Council Members present voting Yes.

MOTION PASSED

4. Pg. 81 - Comprehensive Plan Discussion

- Discussion
- Staff Presentation: Josh Olhava

Josh Olhava, Director of Planning and Economic Development with Ayres, presented to the Town Council the timeline and overview of the Comprehensive Plan update.

D. COUNCIL MEMBER PETITIONS

Council Members may ask for items to be added to future agendas.

Mayor Pro-Tem Vandermark petitioned for a dog treat and stick library at the dog park.
Mayor Fries petitioned for an outdoor skate rink.
Both items will be brought to the Citizen Advisory Board for feedback.

E. ADJOURN

The meeting adjourned at 8:11 p.m.

TOWN OF SEVERANCE

Matthew Fries, Mayor

ATTEST

Sarah Jacobsen, Town Clerk



Thursday, April 16th, 2026

Attn: Town Council and Stakeholders

Re: Financial Statement Review

The Interim Financial Statements for **March 2026** for the Town of Severance have been reviewed and can be published as part of the **April 28th, 2026**, Town Council Consent Agenda.

All the best,

Jacquelyn Grossnickle
Finance Director

TOWN OF SEVERANCE
 COMBINED CASH INVESTMENT
 MARCH 31, 2026

COMBINED CASH ACCOUNTS

01-100700	CASH ON HAND	4,193
01-101000	BANK OF CO- CHECKING ***1469	117,387
01-101500	BANK OF CO CREDIT CARD ***1481	5,451
01-101600	BANK OF CO CASH OUTLAY ***8205	(52,412)
01-102100	COLOTRUST - 8001	19,778,376
01-102110	COLOTRUST - 4001	1,091
01-102180	UMB SAFEKEEPING	47,556,032
01-106000	XPRESS DEPOSIT ACCOUNT	46,613
01-107700	CASH CLEARING - WSFR	(693)
01-107800	CASH CLEARING - SD RE-4	(2,916)
	TOTAL COMBINED CASH	67,453,122
01-100000	CASH ALLOCATED TO OTHER FUNDS	(67,453,122)

TOTAL UNALLOCATED CASH

CASH ALLOCATION RECONCILIATION

10	ALLOCATION TO GENERAL FUND	25,648,280
11	ALLOCATION TO CONSERVATION TRUST FUND	525,746
12	ALLOCATION TO TRANSPORTATION FUND	4,400,718
13	ALLOCATION TO PARKS FUND	617,821
14	ALLOCATION TO PUBLIC FACILITIES FUND	676,930
15	ALLOCATION TO PUBLIC SAFETY FUND	421,324
20	ALLOCATION TO GRANTS FUND	6,792
41	ALLOCATION TO FLEET FUND	293,340
51	ALLOCATION TO WATER FUND	17,958,407
52	ALLOCATION TO WASTEWATER FUND	16,712,793
53	ALLOCATION TO STORMWATER FUND	2,099,168
75	ALLOCATION TO CAPITAL PROJECTS	(1,908,199)
	TOTAL ALLOCATIONS TO OTHER FUNDS	67,453,122
	ALLOCATION FROM COMBINED CASH FUND - 01-100000	(67,453,122)

ZERO PROOF IF ALLOCATIONS BALANCE

TOWN OF SEVERANCE
BALANCE SHEET
MARCH 31, 2026

GENERAL FUND

ASSETS

10-100000	CASH - COMBINED FUND	25,648,280	
10-105000	TAXES RECEIVABLE	1,186,538	
10-105300	CASH W/ WELD COUNTY TREASURER	115,587	
10-115000	ACCOUNTS RECEIVABLE	(128,419)	
10-115010	FUEL INVENTORY	6,366	
10-115011	DIESEL INVENTORY	4,243	
10-115100	OTHER ACCOUNTS RECEIVABLE	3,391	
10-120000	DEVELOPER RECEIVABLES	42,723	
10-131000	DUE FROM OTHER GOVERNMENTS	394,169	
	TOTAL ASSETS		27,272,879

LIABILITIES AND EQUITY

LIABILITIES

10-202000	ACCOUNTS PAYABLE	377,049	
10-203000	CUSTOMER DEPOSITS-DEVELOPERS	66,584	
10-203500	CUSTOMER DEPOSITS-RENTALS	1,900	
10-204000	OTHER ACCRUED EXPENSES	6,435	
10-211400	COLORADO UNEMPLOYMENT PAYABLE	2,089	
10-211650	AFLAC PAYABLE	1,456	
10-211700	HEALTH INSURANCE PAYABLE	(882)	
10-211710	DISABILITY INSURANCE PAYABLE	(5,001)	
10-211755	FSA PAYABLE	(2,672)	
10-211800	DEFERRED PROPERTY TAXES	1,186,538	
10-223000	DEFERRED INFLOWS OF RESOURCES	3,391	
	TOTAL LIABILITIES		1,636,886

FUND EQUITY

UNAPPROPRIATED FUND BALANCE:			
10-290000	FUND BALANCE	25,807,838	
	REVENUE OVER EXPENDITURES - YTD	(171,845)	
	BALANCE - CURRENT DATE		25,635,993
	TOTAL FUND EQUITY		25,635,993
	TOTAL LIABILITIES AND EQUITY		27,272,879

TOWN OF SEVERANCE
REVENUES AND EXPENDITURES WITH COMPARISON TO BUDGET
FOR THE 3 MONTHS ENDING MARCH 31, 2026

GENERAL FUND

	PERIOD ACTUAL	YTD ACTUAL	BUDGET	UNEARNED	PCNT
REVENUE					
<u>TAXES</u>					
10-31-1000	PROPERTY TAX	105,840	950,003	2,140,000	1,189,997 44.4
10-31-3000	SALES TAX	246,632	416,306	2,152,500	1,736,194 19.3
10-31-4000	USE TAX	25,287	86,439	(86,439)	.0
10-31-8100	SEVERANCE TAX (OIL & GAS)		10,000	10,000	.0
10-31-8200	FRANCHISE	27,404	74,020	200,000	125,980 37.0
10-31-9000	INTEREST / DELINQUENT TAX	9	9	1,100	1,091 .8
	TOTAL TAXES	405,172	1,526,777	4,503,600	2,976,823 33.9
<u>LICENSES & PERMITS</u>					
10-32-1000	BUSINESS LICENSE	350	1,475	2,500	1,025 59.0
10-32-1100	LIQUOR LICENSE	175	275	500	225 55.0
10-32-2000	HOME BASED BUSINESS FEES		100	300	200 33.3
10-32-2100	BUILDING PERMIT & LICENSE	22,834	67,676	200,000	132,324 33.8
10-32-2600	ANIMAL LICENSES	40	115	100 (15)	115.0
10-32-3100	PLANNING ADMINISTRATION FEE	559	3,426	29,000	25,574 11.8
10-32-3400	OFFICE ADMINISTRATION FEE	6,644	19,104	100,000	80,896 19.1
10-32-4100	ROW/HUNT/SIGN/DEVELOP. PERMITS	3,100	9,750	25,000	15,250 39.0
10-32-4150	SOLICITOR LICENSES	550	1,110	3,000	1,890 37.0
	TOTAL LICENSES & PERMITS	34,252	103,031	360,400	257,369 28.6
<u>INTERGOVERNMENTAL</u>					
10-33-4000	STATE GRANTS	179	850	(850)	.0
10-33-5000	HIGHWAY USERS	26,009	58,238	419,000	360,762 13.9
10-33-5050	MINERAL LEASE			50,000	50,000 .0
10-33-5100	MOTOR VEHICLE FEES	3,151	9,476	53,500	44,024 17.7
10-33-5200	COUNTY ROAD & BRIDGE	5,362	16,085	32,100	16,015 50.1
10-33-5300	SPECIFIC OWNERSHIP TAX	6,884	21,891	42,800	20,909 51.2
10-33-5600	CIGARETTE TAX	347	629	3,000	2,371 21.0
10-33-6000	SHARED REVENUE WINDSOR			286,000	286,000 .0
	TOTAL INTERGOVERNMENTAL	41,932	107,169	886,400	779,231 12.1
<u>CHARGES FOR SERVICES</u>					
10-34-1100	COURT COSTS	355	2,065	3,000	935 68.8
10-34-1200	POLICE REVENUE		(102)	66,000	66,102 (.2)
10-34-1400	COPIES & REPORTS	158	758	2,000	1,242 37.9
	TOTAL CHARGES FOR SERVICES	513	2,721	71,000	68,279 3.8

TOWN OF SEVERANCE
REVENUES AND EXPENDITURES WITH COMPARISON TO BUDGET
FOR THE 3 MONTHS ENDING MARCH 31, 2026

GENERAL FUND

	PERIOD ACTUAL	YTD ACTUAL	BUDGET	UNEARNED	PCNT
<u>FINES & FORFEITS</u>					
10-35-1000 MUNICIPAL COURT FINES	11,900	45,855	64,000	18,145	71.7
10-35-1100 SURCHARGE	380	2,160	4,000	1,840	54.0
TOTAL FINES & FORFEITS	12,280	48,015	68,000	19,985	70.6
<u>MISCELLANEOUS</u>					
10-36-1000 RETURN CHECK CHARGES	470	1,280	3,000	1,720	42.7
10-36-1500 INSURANCE CLAIM PAYMENTS	1,616	9,392		(9,392)	.0
10-36-2000 OTHER MISCELLANEOUS REVENUE		886	12,000	11,114	7.4
10-36-3000 RENT	7,264	21,793	52,800	31,007	41.3
10-36-3500 INTEREST AND DIVIDENDS	114,224	200,345	802,000	601,655	25.0
10-36-3550 CHANGE IN MARKET VALUE	(638,951)	(611,043)		611,043	.0
10-36-4500 MATERIALS AND LABOR	1,692	3,096	2,000	(1,096)	154.8
10-36-5000 SPECIAL EVENT REVENUE	23,000	23,038	50,000	26,963	46.1
10-36-6500 REIMBURSEMENTS/REFUNDS		2,169		(2,169)	.0
10-36-8050 OIL AND GAS ROYALTIES	14,089	15,060		(15,060)	.0
10-36-9900 OTHER REVENUES	20,150	22,750		(22,750)	.0
TOTAL MISCELLANEOUS	(456,446)	(311,235)	921,800	1,233,035	(33.8)
TOTAL FUND REVENUE	37,703	1,476,478	6,811,200	5,334,722	21.7

TOWN OF SEVERANCE
EXPENDITURES WITH COMPARISON TO BUDGET
FOR THE 3 MONTHS ENDING MARCH 31, 2026

GENERAL FUND

EXPENDITURES	PERIOD ACTUAL	YTD ACTUAL	BUDGET	UNEXPENDED	PCNT
<u>LEGISLATIVE</u>					
10-41-1100 REGULAR STAFF WAGES	2,553	7,263	37,829	30,566	19.2
10-41-1102 OVERTIME			100	100	.0
10-41-1104 RETIREMENT 457	77	214	1,135	921	18.9
10-41-1105 TOWN COUNCIL FEES	3,000	6,743	36,000	29,257	18.7
10-41-1130 FICA/MEDICARE	424	1,070	5,647	4,577	19.0
10-41-1150 UNEMPLOYMENT	5	14	76	62	18.8
10-41-1160 HEALTH INSURANCE	179	537	2,661	2,124	20.2
10-41-1161 DISABILITY INSURANCE	45	90	567	477	15.9
10-41-2100 LEGAL FEES	3,000	3,184	15,000	11,816	21.2
10-41-3180 MILEAGE			300	300	.0
10-41-3320 PRINTING	8,823	17,044	25,200	8,156	67.6
10-41-3330 PUBLISHING/RECORDING			1,000	1,000	.0
10-41-3350 ORDINANCE CODIFICATION			12,000	12,000	.0
10-41-3810 DUES/MEMBERSHIPS/SUBSCRIPTIONS	420	5,903	11,000	5,097	53.7
10-41-3820 CONTINUING EDUCATION	(975)	3,820	24,000	20,180	15.9
10-41-3825 MEETING/MEALS	1,037	3,483	12,100	8,617	28.8
10-41-3990 MISCELLANEOUS		65	600	535	10.8
10-41-3992 COUNCIL SPECIAL EVENTS			5,000	5,000	.0
10-41-4530 VEHICLE & EQUIP AMORTIZATION	165	495	2,000	1,505	24.8
10-41-4810 UNIFORMS		246	6,000	5,754	4.1
10-41-4990 SUPPLIES		25	1,300	1,275	1.9
10-41-5560 CITIZEN ADVISORY BOARD		261	2,000	1,739	13.1
10-41-5570 PLANNING COMMISSION			2,000	2,000	.0
10-41-5580 YOUTH COUNCIL			2,000	2,000	.0
TOTAL LEGISLATIVE	18,753	50,458	205,515	155,057	24.6
<u>ELECTIONS</u>					
10-42-3310 WELD CO COORDINATED ELECTION			15,200	15,200	.0
TOTAL ELECTIONS			15,200	15,200	.0

TOWN OF SEVERANCE
EXPENDITURES WITH COMPARISON TO BUDGET
FOR THE 3 MONTHS ENDING MARCH 31, 2026

GENERAL FUND

	PERIOD ACTUAL	YTD ACTUAL	BUDGET	UNEXPENDED	PCNT
<u>JUDICIAL</u>					
10-43-1100 REGULAR STAFF WAGES	2,146	6,001	29,287	23,286	20.5
10-43-1102 OVERTIME			100	100	.0
10-43-1104 RETIREMENT 457	64	180	879	699	20.5
10-43-1130 FICA/MEDICARE	160	446	2,240	1,794	19.9
10-43-1150 UNEMPLOYMENT	4	12	59	47	20.4
10-43-1160 HEALTH INSURANCE	448	1,344	5,375	4,031	25.0
10-43-1161 DISABILITY INSURANCE	43	43	439	396	9.7
10-43-2100 LEGAL FEES	850	2,550	15,000	12,450	17.0
10-43-2110 MUNICIPAL JUDGE	800	2,400	10,500	8,100	22.9
10-43-3820 EDUCATION			1,500	1,500	.0
10-43-3830 TRANSLATOR/JUROR FEES	91	221	400	179	55.3
10-43-4310 COURT SUPPLIES		107	200	93	53.3
10-43-4810 UNIFORMS			1,400	1,400	.0
TOTAL JUDICIAL	4,605	13,304	67,379	54,075	19.7

TOWN OF SEVERANCE
EXPENDITURES WITH COMPARISON TO BUDGET
FOR THE 3 MONTHS ENDING MARCH 31, 2026

GENERAL FUND

	PERIOD ACTUAL	YTD ACTUAL	BUDGET	UNEXPENDED	PCNT
<u>MANAGEMENT</u>					
10-44-1100	15,392	42,979	194,199	151,220	22.1
10-44-1101	379	1,122	28,776	27,654	3.9
10-44-1102	38	38	400	362	9.4
10-44-1104	761	2,125	9,719	7,594	21.9
10-44-1130	1,215	3,393	17,057	13,664	19.9
10-44-1140	17,608	35,215	75,600	40,385	46.6
10-44-1150	33	91	445	354	20.5
10-44-1160	2,113	6,339	25,332	18,993	25.0
10-44-1161	170	334	3,252	2,918	10.3
10-44-1164		1,780	2,000	220	89.0
10-44-2150		4,175	50,000	45,825	8.4
10-44-2990			7,000	7,000	.0
10-44-3110	20,386	54,056	262,200	208,144	20.6
10-44-3150	4,174	10,961	40,000	29,039	27.4
10-44-3175	975	2,641	17,000	14,359	15.5
10-44-3177			2,500	2,500	.0
10-44-3210	66,478	144,911	274,200	129,289	52.9
10-44-3220	1,692	13,023	15,000	1,977	86.8
10-44-3810		2,340	3,500	1,160	66.9
10-44-3820	(100)	1,807	12,000	10,193	15.1
10-44-3825	224	679	5,000	4,321	13.6
10-44-3992	15,811	36,059	175,000	138,941	20.6
10-44-4000	51	51	2,000	1,949	2.6
10-44-4320	12,503	14,707	40,000	25,293	36.8
10-44-4330	28,084	162,270	356,630	194,360	45.5
10-44-4350	1,482	4,484	10,000	5,516	44.8
10-44-4360	600	1,630	15,000	13,370	10.9
10-44-4520	93	294	1,000	706	29.4
10-44-4530	295	885	3,600	2,715	24.6
10-44-4810			1,500	1,500	.0
10-44-4850	2,136	4,294	25,000	20,706	17.2
10-44-4990	91	216	3,000	2,784	7.2
10-44-8000	256	256	1,100	844	23.3
TOTAL MANAGEMENT	192,941	553,155	1,679,010	1,125,855	33.0

TOWN OF SEVERANCE
EXPENDITURES WITH COMPARISON TO BUDGET
FOR THE 3 MONTHS ENDING MARCH 31, 2026

GENERAL FUND

	PERIOD ACTUAL	YTD ACTUAL	BUDGET	UNEXPENDED	PCNT
<u>FINANCE</u>					
10-45-1100 REGULAR STAFF WAGES	5,379	16,318	95,475	79,157	17.1
10-45-1102 OVERTIME			100	100	.0
10-45-1104 RETIREMENT 457	161	469	2,865	2,396	16.4
10-45-1130 FICA/MEDICARE	383	1,183	7,304	6,121	16.2
10-45-1150 UNEMPLOYMENT	11	33	192	159	17.0
10-45-1160 HEALTH & LIFE INSURANCE	709	2,307	11,205	8,898	20.6
10-45-1161 DISABILITY INSURANCE	112	388	1,432	1,044	27.1
10-45-2200 AUDIT & ACCOUNTING FEES			35,000	35,000	.0
10-45-3315 WELD COUNTY TREASURER FEE	1,059	9,522	21,900	12,378	43.5
10-45-3340 BANK CHARGES	10	50	1,500	1,450	3.3
10-45-3810 DUES/MEMBERSHIPS/SUBSCRIPTIONS		65	1,000	935	6.5
10-45-3820 CONTINUING EDUCATION	170	469	7,000	6,531	6.7
10-45-3825 MEALS/MISCELLANEOUS			1,000	1,000	.0
10-45-4810 UNIFORMS			2,100	2,100	.0
TOTAL FINANCE	7,994	30,803	188,073	157,270	16.4
<u>ADMINISTRATIVE SERVICES</u>					
10-46-1100 REGULAR STAFF WAGES	13,356	37,117	169,314	132,197	21.9
10-46-1102 OVERTIME			100	100	.0
10-46-1104 RETIREMENT 457	397	1,110	5,176	4,067	21.4
10-46-1130 FICA/MEDICARE	982	2,747	12,952	10,205	21.2
10-46-1150 UNEMPLOYMENT	27	74	339	265	21.9
10-46-1160 HEALTH INSURANCE	1,971	5,912	23,651	17,739	25.0
10-46-1161 DISABILITY INSURANCE	259	458	2,540	2,082	18.0
10-46-1170 RETENTION	1,577	1,616	10,000	8,384	16.2
10-46-3810 DUES/MEMBERSHIPS/SUBSCRIPTIONS		180	500	320	36.0
10-46-3820 CONTINUING EDUCATION		669	4,500	3,831	14.9
10-46-3825 MEETING/MEALS			1,000	1,000	.0
10-46-3990 MISCELLANEOUS	767	1,520	7,200	5,680	21.1
10-46-4310 OFFICE SUPPLIES	1,360	2,113	8,000	5,887	26.4
10-46-4340 POSTAGE		20	6,000	5,980	.3
10-46-4810 UNIFORMS			1,800	1,800	.0
TOTAL ADMINISTRATIVE SERVICES	20,696	53,536	253,072	199,536	21.2

TOWN OF SEVERANCE
EXPENDITURES WITH COMPARISON TO BUDGET
FOR THE 3 MONTHS ENDING MARCH 31, 2026

GENERAL FUND

	PERIOD ACTUAL	YTD ACTUAL	BUDGET	UNEXPENDED	PCNT
<u>PUBLIC SAFETY</u>					
10-51-1100	117,909	338,989	1,510,195	1,171,206	22.5
10-51-1102	2,138	4,678	30,000	25,322	15.6
10-51-1104	441	1,233	5,750	4,517	21.5
10-51-1107	264	1,487	10,000	8,513	14.9
10-51-1130	2,549	7,305	33,781	26,476	21.6
10-51-1150	241	690	3,020	2,330	22.9
10-51-1155	10,420	29,640	197,783	168,143	15.0
10-51-1160	14,184	42,551	166,548	123,997	25.6
10-51-1161	5,763	14,220	22,652	8,432	62.8
10-51-2300			1,000	1,000	.0
10-51-2310			2,500	2,500	.0
10-51-2900	5,073	40,389	40,215	(174)	100.4
10-51-2990		245	15,000	14,755	1.6
10-51-3173			500	500	.0
10-51-3175	1,182	6,738	15,000	8,262	44.9
10-51-3177	10,398	15,221	70,000	54,779	21.7
10-51-3320	108	297	2,500	2,203	11.9
10-51-3610			94,000	94,000	.0
10-51-3630			12,000	12,000	.0
10-51-3640			1,000	1,000	.0
10-51-3650	700	700	1,000	300	70.0
10-51-3740			1,000	1,000	.0
10-51-3810		1,110	2,300	1,190	48.3
10-51-3820	2,838	11,369	15,000	3,631	75.8
10-51-3825	589	784	4,000	3,216	19.6
10-51-3850			1,200	1,200	.0
10-51-3950			2,000	2,000	.0
10-51-3990	77	77	500	423	15.4
10-51-3992			2,000	2,000	.0
10-51-4300	360	360	500	140	72.0
10-51-4310	372	1,409	2,000	591	70.4
10-51-4520	2,195	7,065	29,000	21,935	24.4
10-51-4530	4,221	12,662	105,300	92,638	12.0
10-51-4720	406	1,702	4,000	2,298	42.6
10-51-4730	126	537	4,000	3,463	13.4
10-51-4740		1,086	1,500	414	72.4
10-51-4750		231	7,000	6,769	3.3
10-51-4810	513	513	16,000	15,487	3.2
10-51-4990		120	1,000	880	12.0
TOTAL PUBLIC SAFETY	183,068	543,408	2,432,744	1,889,336	22.3

TOWN OF SEVERANCE
EXPENDITURES WITH COMPARISON TO BUDGET
FOR THE 3 MONTHS ENDING MARCH 31, 2026

GENERAL FUND

	PERIOD ACTUAL	YTD ACTUAL	BUDGET	UNEXPENDED	PCNT
<u>STREETS / MAINTENANCE</u>					
10-61-1100	16,458	53,203	300,930	247,727	17.7
10-61-1101			9,674	9,674	.0
10-61-1102	115	1,272	2,700	1,428	47.1
10-61-1104	515	1,643	9,029	7,386	18.2
10-61-1130	1,134	3,972	23,021	19,049	17.3
10-61-1150	35	115	603	488	19.1
10-61-1160	3,204	11,402	49,971	38,569	22.8
10-61-1161	428	823	4,515	3,692	18.2
10-61-3162			20,000	20,000	.0
10-61-3172		1,513	163,000	161,487	.9
10-61-3820		600	2,800	2,200	21.4
10-61-4311			4,500	4,500	.0
10-61-4530	1,285	3,855	22,500	18,645	17.1
10-61-4810		157	1,500	1,343	10.4
10-61-4990	702	843	2,500	1,657	33.7
10-61-5000	1,224	7,577	15,000	7,423	50.5
	25,100	86,975	632,243	545,268	13.8
<u>SNOW</u>					
10-63-1100	1,111	4,002	12,000	7,998	33.4
10-63-1102		3,639	12,000	8,361	30.3
10-63-4110		21,842	68,000	46,158	32.1
10-63-4520	175	619	1,500	881	41.3
10-63-4530	2,083	6,250	25,000	18,750	25.0
	3,369	36,352	118,500	82,148	30.7
<u>PUBLIC WORKS OVERHEAD</u>					
10-64-1102			3,500	3,500	.0
10-64-2990	735	1,290	2,500	1,210	51.6
10-64-3173	7,928	32,856	53,000	20,145	62.0
10-64-3175	1,074	2,448	21,000	18,552	11.7
10-64-3177	2,241	8,080	25,000	16,920	32.3
10-64-3690			40,000	40,000	.0
10-64-3825		216	3,000	2,784	7.2
10-64-3990	487	902	2,000	1,098	45.1
10-64-4320			2,500	2,500	.0
10-64-4520	1,455	3,941	22,000	18,059	17.9
10-64-4810		290	500	210	58.0
10-64-4990	772	1,932	5,000	3,068	38.6
10-64-5001		43	2,000	1,957	2.2
	14,691	51,997	182,000	130,003	28.6

TOWN OF SEVERANCE
EXPENDITURES WITH COMPARISON TO BUDGET
FOR THE 3 MONTHS ENDING MARCH 31, 2026

GENERAL FUND

	PERIOD ACTUAL	YTD ACTUAL	BUDGET	UNEXPENDED	PCNT
<u>PARKS / GREEN SPACE</u>					
10-65-1100	19,191	49,326	223,454	174,128	22.1
10-65-1101			58,044	58,044	.0
10-65-1102	143	143	2,800	2,657	5.1
10-65-1104	576	1,502	6,703	5,201	22.4
10-65-1130	1,328	3,678	21,534	17,856	17.1
10-65-1150	39	104	561	457	18.5
10-65-1160	2,893	8,678	35,228	26,550	24.6
10-65-1161	346	658	4,222	3,564	15.6
10-65-3171		220	3,500	3,280	6.3
10-65-3176		394	21,000	20,606	1.9
10-65-3185			10,000	10,000	.0
10-65-3186			3,000	3,000	.0
10-65-3810			1,000	1,000	.0
10-65-3820		82	3,000	2,918	2.7
10-65-3990		1,260	5,000	3,740	25.2
10-65-4530	243	730	10,000	9,270	7.3
10-65-4810		155	1,100	945	14.1
10-65-4990	1,457	3,599	10,000	6,401	36.0
10-65-6000		68	23,000	22,932	.3
10-65-7990			2,000	2,000	.0
	<u>26,216</u>	<u>70,596</u>	<u>445,146</u>	<u>374,550</u>	<u>15.9</u>
<u>PLANNING</u>					
10-70-1100	13,646	38,169	177,402	139,233	21.5
10-70-1101			6,147	6,147	.0
10-70-1102			100	100	.0
10-70-1104	409	1,145	5,322	4,177	21.5
10-70-1130	1,024	2,874	14,041	11,167	20.5
10-70-1150	27	76	367	291	20.8
10-70-1160	1,794	5,381	21,524	16,143	25.0
10-70-1161	269	516	2,661	2,145	19.4
10-70-2400	5,559	12,746	75,000	62,254	17.0
10-70-2600	3,617	6,367	50,000	43,634	12.7
10-70-2980	26,832	44,189	200,000	155,811	22.1
10-70-3810			3,000	3,000	.0
10-70-3820			5,500	5,500	.0
10-70-3825	120	120	1,000	880	12.0
10-70-4099	8,183	30,662	(30,662)	.0
10-70-4530	165	495	2,000	1,505	24.8
10-70-4810			500	500	.0
10-70-4989		15,000	15,000		100.0
	<u>61,644</u>	<u>157,740</u>	<u>579,564</u>	<u>421,824</u>	<u>27.2</u>
	<u>559,077</u>	<u>1,648,324</u>	<u>6,798,446</u>	<u>5,150,122</u>	<u>24.3</u>

TOWN OF SEVERANCE
 EXPENDITURES WITH COMPARISON TO BUDGET
 FOR THE 3 MONTHS ENDING MARCH 31, 2026

GENERAL FUND

	PERIOD ACTUAL	YTD ACTUAL	BUDGET	UNEXPENDED	PCNT
NET REVENUE OVER EXPENDITURES	(521,374)	(171,845)	12,754	184,599	(1347.

TOWN OF SEVERANCE
 BALANCE SHEET
 MARCH 31, 2026

CONSERVATION TRUST FUND

ASSETS

11-100000	CASH - COMBINED FUND		525,746	
	TOTAL ASSETS			525,746

LIABILITIES AND EQUITY

FUND EQUITY

	UNAPPROPRIATED FUND BALANCE:			
11-290000	FUND BALANCE	474,804		
	REVENUE OVER EXPENDITURES - YTD	50,942		
	BALANCE - CURRENT DATE		525,746	
	TOTAL FUND EQUITY			525,746
	TOTAL LIABILITIES AND EQUITY			525,746

TOWN OF SEVERANCE
REVENUES AND EXPENDITURES WITH COMPARISON TO BUDGET
FOR THE 3 MONTHS ENDING MARCH 31, 2026

CONSERVATION TRUST FUND

		PERIOD ACTUAL	YTD ACTUAL	BUDGET	UNEARNED	PCNT
REVENUE						
<u>INTERGOVERNMENTAL</u>						
11-33-5900	COLORADO LOTTERY	42,839	42,839		(42,839)	.0
	TOTAL INTERGOVERNMENTAL	42,839	42,839		(42,839)	.0
<u>MISCELLANEOUS</u>						
11-36-3500	INTEREST AND DIVIDENDS	2,411	4,519	12,000	7,481	37.7
11-36-3550	CHANGE IN MARKET VALUE	2,901	3,584		(3,584)	.0
	TOTAL MISCELLANEOUS	5,312	8,103	12,000	3,897	67.5
	TOTAL FUND REVENUE	48,151	50,942	12,000	(38,942)	424.5
	NET REVENUE OVER EXPENDITURES	48,151	50,942	12,000	(38,942)	424.5

TOWN OF SEVERANCE
 BALANCE SHEET
 MARCH 31, 2026

TRANSPORTATION FUND

ASSETS

12-100000	CASH - COMBINED FUND		4,400,718	
12-115000	ACCOUNTS RECEIVABLE		66,354	
			<u> </u>	
	TOTAL ASSETS			<u>4,467,072</u>

LIABILITIES AND EQUITY

FUND EQUITY

	UNAPPROPRIATED FUND BALANCE:			
12-290000	FUND BALANCE	4,143,711		
	REVENUE OVER EXPENDITURES - YTD	323,361		
		<u> </u>		
	BALANCE - CURRENT DATE		4,467,072	
			<u> </u>	
	TOTAL FUND EQUITY			<u>4,467,072</u>
				<u> </u>
	TOTAL LIABILITIES AND EQUITY			<u>4,467,072</u>

TOWN OF SEVERANCE
REVENUES AND EXPENDITURES WITH COMPARISON TO BUDGET
FOR THE 3 MONTHS ENDING MARCH 31, 2026

TRANSPORTATION FUND

	PERIOD ACTUAL	YTD ACTUAL	BUDGET	UNEARNED	PCNT
REVENUE					
<u>IMPACT FEES</u>					
12-34-1000	64,344	192,806	766,300	573,494	25.2
12-34-3000	6,075	60,750		(60,750)	.0
	<u>70,419</u>	<u>253,556</u>	<u>766,300</u>	<u>512,744</u>	<u>33.1</u>
<u>MISCELLANEOUS</u>					
12-36-3500	20,325	38,928	137,000	98,072	28.4
12-36-3550	24,849	30,877		(30,877)	.0
	<u>45,174</u>	<u>69,805</u>	<u>137,000</u>	<u>67,195</u>	<u>51.0</u>
	<u>115,593</u>	<u>323,361</u>	<u>903,300</u>	<u>579,939</u>	<u>35.8</u>
	<u>115,593</u>	<u>323,361</u>	<u>903,300</u>	<u>579,939</u>	<u>35.8</u>

TOWN OF SEVERANCE
 BALANCE SHEET
 MARCH 31, 2026

PARKS FUND

<u>ASSETS</u>			
13-100000	CASH - COMBINED FUND		617,821
	TOTAL ASSETS		617,821
 <u>LIABILITIES AND EQUITY</u>			
 <u>FUND EQUITY</u>			
UNAPPROPRIATED FUND BALANCE:			
13-290000	FUND BALANCE	595,786	
	REVENUE OVER EXPENDITURES - YTD	22,035	
	BALANCE - CURRENT DATE		617,821
	TOTAL FUND EQUITY		617,821
	TOTAL LIABILITIES AND EQUITY		617,821

TOWN OF SEVERANCE
REVENUES AND EXPENDITURES WITH COMPARISON TO BUDGET
FOR THE 3 MONTHS ENDING MARCH 31, 2026

PARKS FUND

		PERIOD ACTUAL	YTD ACTUAL	BUDGET	UNEARNED	PCNT
REVENUE						
<u>IMPACT FEES</u>						
13-34-7400	PARK IMPACT FEE	1,645	12,009		(12,009)	.0
	TOTAL IMPACT FEES	1,645	12,009		(12,009)	.0
<u>MISCELLANEOUS</u>						
13-36-3500	INTEREST AND DIVIDENDS	2,911	5,591	17,000	11,409	32.9
13-36-3550	CHANGE IN MARKET VALUE	3,566	4,435		(4,435)	.0
	TOTAL MISCELLANEOUS	6,477	10,026	17,000	6,974	59.0
	TOTAL FUND REVENUE	8,122	22,035	17,000	(5,035)	129.6
	NET REVENUE OVER EXPENDITURES	8,122	22,035	17,000	(5,035)	129.6

TOWN OF SEVERANCE
 BALANCE SHEET
 MARCH 31, 2026

PUBLIC FACILITIES FUND

ASSETS

14-100000	CASH – COMBINED FUND		676,930	
	TOTAL ASSETS			676,930

LIABILITIES AND EQUITY

FUND EQUITY

	UNAPPROPRIATED FUND BALANCE:			
14-290000	FUND BALANCE	640,210		
	REVENUE OVER EXPENDITURES - YTD	36,720		
	BALANCE - CURRENT DATE		676,930	
	TOTAL FUND EQUITY			676,930
	TOTAL LIABILITIES AND EQUITY			676,930

TOWN OF SEVERANCE
REVENUES AND EXPENDITURES WITH COMPARISON TO BUDGET
FOR THE 3 MONTHS ENDING MARCH 31, 2026

PUBLIC FACILITIES FUND

		PERIOD ACTUAL	YTD ACTUAL	BUDGET	UNEARNED	PCNT
REVENUE						
<u>IMPACT FEES</u>						
14-32-3000	GENERAL GOVERNMENT IMPACT FEE	2,611	26,110		(26,110)	.0
	TOTAL IMPACT FEES	2,611	26,110		(26,110)	.0
<u>MISCELLANEOUS</u>						
14-36-3500	INTEREST AND DIVIDENDS	3,132	5,917	18,000	12,083	32.9
14-36-3550	CHANGE IN MARKET VALUE	3,791	4,693		(4,693)	.0
	TOTAL MISCELLANEOUS	6,922	10,610	18,000	7,390	59.0
	TOTAL FUND REVENUE	9,533	36,720	18,000	(18,720)	204.0
	NET REVENUE OVER EXPENDITURES	9,533	36,720	18,000	(18,720)	204.0

TOWN OF SEVERANCE
 BALANCE SHEET
 MARCH 31, 2026

PUBLIC SAFETY FUND

ASSETS

15-100000	CASH – COMBINED FUND		421,324	
	TOTAL ASSETS			421,324

LIABILITIES AND EQUITY

FUND EQUITY

UNAPPROPRIATED FUND BALANCE:				
15-290000	FUND BALANCE		407,060	
	REVENUE OVER EXPENDITURES - YTD		14,264	
	BALANCE - CURRENT DATE		421,324	
	TOTAL FUND EQUITY			421,324
	TOTAL LIABILITIES AND EQUITY			421,324

TOWN OF SEVERANCE
REVENUES AND EXPENDITURES WITH COMPARISON TO BUDGET
FOR THE 3 MONTHS ENDING MARCH 31, 2026

PUBLIC SAFETY FUND

		PERIOD ACTUAL	YTD ACTUAL	BUDGET	UNEARNED	PCNT
REVENUE						
<u>IMPACT FEES</u>						
15-32-3000	POLICE IMPACT FEE	749	7,490		(7,490)	.0
	TOTAL IMPACT FEES	749	7,490		(7,490)	.0
<u>MISCELLANEOUS</u>						
15-36-3500	INTEREST AND DIVIDENDS	1,975	3,777	12,000	8,223	31.5
15-36-3550	CHANGE IN MARKET VALUE	2,412	2,996		(2,996)	.0
	TOTAL MISCELLANEOUS	4,388	6,774	12,000	5,226	56.5
	TOTAL FUND REVENUE	5,137	14,264	12,000	(2,264)	118.9
	NET REVENUE OVER EXPENDITURES	5,137	14,264	12,000	(2,264)	118.9

TOWN OF SEVERANCE
 BALANCE SHEET
 MARCH 31, 2026

GRANTS FUND

ASSETS

20-100000	CASH - COMBINED FUND	6,792	
	TOTAL ASSETS		<u>6,792</u>

LIABILITIES AND EQUITY

FUND EQUITY

20-290000	UNAPPROPRIATED FUND BALANCE: FUND BALANCE	6,792	
	BALANCE - CURRENT DATE	6,792	
	TOTAL FUND EQUITY		<u>6,792</u>
	TOTAL LIABILITIES AND EQUITY		<u>6,792</u>

TOWN OF SEVERANCE
BALANCE SHEET
MARCH 31, 2026

FLEET FUND

ASSETS

41-100000	CASH - COMBINED FUND	293,340	
	TOTAL ASSETS		293,340

LIABILITIES AND EQUITY

LIABILITIES

41-202000	ACCOUNTS PAYABLE	(206,605)	
	TOTAL LIABILITIES		(206,605)

FUND EQUITY

UNAPPROPRIATED FUND BALANCE:			
41-290000	FUND BALANCE	673,173	
	REVENUE OVER EXPENDITURES - YTD	(173,227)	
	BALANCE - CURRENT DATE	499,946	
	TOTAL FUND EQUITY		499,946
	TOTAL LIABILITIES AND EQUITY		293,340

TOWN OF SEVERANCE
 REVENUES AND EXPENDITURES WITH COMPARISON TO BUDGET
 FOR THE 3 MONTHS ENDING MARCH 31, 2026

FLEET FUND

		PERIOD ACTUAL	YTD ACTUAL	BUDGET	UNEARNED	PCNT
REVENUE						
<u>CHARGES FOR SERVICES</u>						
41-34-2000	FLEET REPLACEMENT REVENUE	8,752	26,256	188,000	161,744	14.0
	TOTAL CHARGES FOR SERVICES	8,752	26,256	188,000	161,744	14.0
<u>MISCELLANEOUS</u>						
41-36-3500	INTEREST AND DIVIDENDS	1,746	3,971	18,000	14,029	22.1
41-36-3550	CHANGE IN MARKET VALUE	2,429	3,150		(3,150)	.0
	TOTAL MISCELLANEOUS	4,175	7,122	18,000	10,878	39.6
	TOTAL FUND REVENUE	12,927	33,378	206,000	172,622	16.2

TOWN OF SEVERANCE
EXPENDITURES WITH COMPARISON TO BUDGET
FOR THE 3 MONTHS ENDING MARCH 31, 2026

FLEET FUND

EXPENDITURES	PERIOD ACTUAL	YTD ACTUAL	BUDGET	UNEXPENDED	PCNT
<u>OPERATIONS</u>					
41-60-7550 VEHICLES		163,630	683,000	519,370	24.0
41-60-7580 EQUIPMENT		42,975	86,500	43,525	49.7
TOTAL OPERATIONS		206,605	769,500	562,895	26.9
TOTAL FUND EXPENDITURES		206,605	769,500	562,895	26.9
NET REVENUE OVER EXPENDITURES	12,927	(173,227)	(563,500)	(390,273)	(30.7)

TOWN OF SEVERANCE
BALANCE SHEET
MARCH 31, 2026

WATER FUND

ASSETS

51-100000	CASH - COMBINED FUND	17,958,407	
51-115000	ACCOUNTS RECEIVABLE	219,430	
51-115005	PARTS INVENTORY	47,130	
51-161000	LAND	294,759	
51-162100	ACCUMULATED DEPRECIATION	(1,956,288)	
51-163000	WATER SYSTEM	10,441,728	
51-164000	EQUIPMENT	197,758	
51-165000	CONSTRUCTION IN PROGRESS	5,771,326	
51-166000	WATER RIGHTS	35,151,374	
51-167000	WATER CAPACITY	4,880,334	
51-168000	BUILDINGS	1,010,077	
51-168500	NISP PROJECT	2,031,177	
	TOTAL ASSETS		76,047,212

LIABILITIES AND EQUITY

LIABILITIES

51-202000	ACCOUNTS PAYABLE	44,115	
51-212000	ACCRUED COMPENSATED ABSENCES	16,089	
51-222000	HYDRANT METER DEPOSITS	3,500	
	TOTAL LIABILITIES		63,704

FUND EQUITY

51-273000	CONTRIBUTED CAPITAL - DEVELOPM	6,848,000	
	UNAPPROPRIATED FUND BALANCE:		
51-290000	RETAINED EARNINGS	70,559,979	
	REVENUE OVER EXPENDITURES - YTD	(1,424,471)	
	BALANCE - CURRENT DATE	69,135,508	
	TOTAL FUND EQUITY		75,983,508
	TOTAL LIABILITIES AND EQUITY		76,047,212

TOWN OF SEVERANCE
REVENUES AND EXPENDITURES WITH COMPARISON TO BUDGET
FOR THE 3 MONTHS ENDING MARCH 31, 2026

WATER FUND

	PERIOD ACTUAL	YTD ACTUAL	BUDGET	UNEARNED	PCNT
REVENUE					
<u>CHARGES FOR SERVICES</u>					
51-34-1000 WATER UTILITY	210,286	634,445	2,895,200	2,260,755	21.9
TOTAL CHARGES FOR SERVICES	210,286	634,445	2,895,200	2,260,755	21.9
<u>RESTRICTED</u>					
51-35-6500 RAW WATER ACQUISITION FEE	63,500	155,300		(155,300)	.0
51-35-7150 WATER UTILITY IMPACT FEE	16,975	169,750		(169,750)	.0
TOTAL RESTRICTED	80,475	325,050		(325,050)	.0
<u>MISCELLANEOUS</u>					
51-36-2000 WATER PIT/METER SET FEE	389	3,889	10,000	6,111	38.9
51-36-3500 INTEREST AND DIVIDENDS	85,583	167,460	549,000	381,540	30.5
51-36-3550 CHANGE IN MARKET VALUE	106,297	132,830		(132,830)	.0
TOTAL MISCELLANEOUS	192,268	304,179	559,000	254,821	54.4
TOTAL FUND REVENUE	483,029	1,263,674	3,454,200	2,190,526	36.6

TOWN OF SEVERANCE
EXPENDITURES WITH COMPARISON TO BUDGET
FOR THE 3 MONTHS ENDING MARCH 31, 2026

WATER FUND

EXPENDITURES	PERIOD ACTUAL	YTD ACTUAL	BUDGET	UNEXPENDED	PCNT
<u>ADMINISTRATION</u>					
51-81-1100 REGULAR STAFF WAGES	36,806	112,468	598,805	486,337	18.8
51-81-1102 OVERTIME	357	666	5,100	4,434	13.1
51-81-1104 RETIREMENT	1,709	4,914	25,752	20,838	19.1
51-81-1130 FICA/MEDICARE	2,799	8,412	45,808	37,396	18.4
51-81-1150 UNEMPLOYMENT	75	228	902	674	25.3
51-81-1160 HEALTH & LIFE INSURANCE	4,854	15,527	73,110	57,583	21.2
51-81-1161 DISABILITY INSURANCE	701	1,394	9,278	7,884	15.0
51-81-2100 LEGAL FEES			15,000	15,000	.0
51-81-2990 OTHER PROFESSIONAL FEES	10,589	20,438	110,000	89,562	18.6
51-81-3110 UTILITIES	1,374	3,469	40,800	37,331	8.5
51-81-3162 CC FEES	2,753	8,883	27,000	18,117	32.9
51-81-3810 DUES/MEMBERSHIPS/SUBSCRIPTIONS	1,100	2,203	2,500	298	88.1
51-81-3820 CONTINUING EDUCATION			7,500	7,500	.0
51-81-3990 MISCELLANEOUS SERVICES	361	778	6,000	5,222	13.0
51-81-4345 MAILING SERVICE	930	4,095	15,000	10,905	27.3
51-81-4810 UNIFORMS	260	340	1,500	1,160	22.7
51-81-4990 MISCELLANEOUS SUPPLIES	410	629	8,500	7,871	7.4
51-81-5000 UTILITY BILL ADJUSTMENTS	(301)				.0
TOTAL ADMINISTRATION	64,776	184,444	992,555	808,112	18.6
<u>WATER OPERATIONS</u>					
51-82-1130 FICA/MEDICARE	(61)				.0
51-82-2400 ENGINEERING	2,665	5,102	35,000	29,899	14.6
51-82-2410 WATER SYSTEM IMPROVE. PERMIT			1,000	1,000	.0
51-82-3173 REPAIRS & MAINTENANCE - EQUIPM			6,000	6,000	.0
51-82-3177 VEHICLE REPAIRS & MAINTENANCE		77	5,000	4,923	1.5
51-82-3178 SYSTEM REPAIR & MAINTENANCE		258	40,000	39,742	.7
51-82-3200 SAMPLING/TESTING		471	500	30	94.1
51-82-4120 WATER SYSTEM SUPPLIES			3,000	3,000	.0
51-82-4130 METER SET SUPPLIES	1,467	3,379	35,000	31,622	9.7
51-82-4520 VEHICLE FUEL	447	1,363	10,000	8,637	13.6
51-82-4530 VEHICLE & EQUIP AMORTIZATION	147	442	8,800	8,358	5.0
51-82-4850 UNANTICIPATED EXP/CONTINGENCY			20,000	20,000	.0
51-82-4995 WATER TREATMENT & DISTRIBUTION	43,479	139,742	1,212,800	1,073,058	11.5
51-82-4997 WATER SHARE ASSESSMENTS	1,050	16,450	125,000	108,550	13.2
TOTAL WATER OPERATIONS	49,195	167,282	1,502,100	1,334,818	11.1

TOWN OF SEVERANCE
EXPENDITURES WITH COMPARISON TO BUDGET
FOR THE 3 MONTHS ENDING MARCH 31, 2026

WATER FUND

	PERIOD ACTUAL	YTD ACTUAL	BUDGET	UNEXPENDED	PCNT
<u>WATER CAPITAL</u>					
51-83-2400 ENGINEERING			205,000	205,000	.0
51-83-7000 CAPITAL OUTLAY			300,000	300,000	.0
51-83-7500 CONSTRUCTION	336	50,420	6,142,914	6,092,494	.8
51-83-7565 SYSTEM IMPROVEMENTS			2,225,000	2,225,000	.0
TOTAL WATER CAPITAL	336	50,420	8,872,914	8,822,494	.6
<u>LOCAL PLANT INVESTMENT EXPENSE</u>					
51-84-7550 SYSTEM IMPROVEMENTS		2,286,000	2,286,000		100.0
TOTAL LOCAL PLANT INVESTMENT EXPENS		2,286,000	2,286,000		100.0
TOTAL FUND EXPENDITURES	114,307	2,688,145	13,653,569	10,965,424	19.7
NET REVENUE OVER EXPENDITURES	368,722	(1,424,471)	(10,199,369)	(8,774,898)	(14.0)

TOWN OF SEVERANCE
BALANCE SHEET
MARCH 31, 2026

WASTEWATER FUND

ASSETS

52-100000	CASH - COMBINED FUND	16,712,793	
52-115000	ACCOUNTS RECEIVABLE	148,437	
52-115002	MISCELLANEOUS RECEIVABLE	111,517	
52-162100	ACCUMULATED DEPRECIATION	(4,462,270)	
52-163000	SEWER SYSTEM	19,515,535	
52-164000	EQUIPMENT	204,164	
52-165000	CONSTRUCTION IN PROGRESS	352,378	
52-168000	BUILDINGS	653,477	
	TOTAL ASSETS		33,236,030

LIABILITIES AND EQUITY

LIABILITIES

52-202000	ACCOUNTS PAYABLE	14,297	
52-212000	ACCRUED COMPENSATED ABSENCES	13,904	
	TOTAL LIABILITIES		28,201

FUND EQUITY

UNAPPROPRIATED FUND BALANCE:			
52-290000	RETAINED EARNINGS	32,598,974	
	REVENUE OVER EXPENDITURES - YTD	608,856	
	BALANCE - CURRENT DATE	33,207,829	
	TOTAL FUND EQUITY		33,207,829
	TOTAL LIABILITIES AND EQUITY		33,236,030

TOWN OF SEVERANCE
REVENUES AND EXPENDITURES WITH COMPARISON TO BUDGET
FOR THE 3 MONTHS ENDING MARCH 31, 2026

WASTEWATER FUND

		PERIOD ACTUAL	YTD ACTUAL	BUDGET	UNEARNED	PCNT
REVENUE						
<u>CHARGES FOR SERVICES</u>						
52-34-1000	WASTEWATER UTILITY	148,059	436,396	1,596,700	1,160,304	27.3
	TOTAL CHARGES FOR SERVICES	148,059	436,396	1,596,700	1,160,304	27.3
<u>RESTRICTED</u>						
52-35-7100	WASTEWATER UTILITY IMPACT FEE	14,796	147,960		(147,960)	.0
	TOTAL RESTRICTED	14,796	147,960		(147,960)	.0
<u>MISCELLANEOUS</u>						
52-36-3500	INTEREST AND DIVIDENDS	78,161	150,274	455,000	304,726	33.0
52-36-3550	CHANGE IN MARKET VALUE	95,829	119,197		(119,197)	.0
	TOTAL MISCELLANEOUS	173,990	269,471	455,000	185,529	59.2
	TOTAL FUND REVENUE	336,844	853,827	2,051,700	1,197,873	41.6

TOWN OF SEVERANCE
EXPENDITURES WITH COMPARISON TO BUDGET
FOR THE 3 MONTHS ENDING MARCH 31, 2026

WASTEWATER FUND

		PERIOD ACTUAL	YTD ACTUAL	BUDGET	UNEXPENDED	PCNT
EXPENDITURES						
<u>WASTEWATER ADMINISTRATION</u>						
52-81-1100	REGULAR STAFF WAGES	36,362	111,225	593,599	482,374	18.7
52-81-1102	OVERTIME	357	666	4,800	4,134	13.9
52-81-1104	RETIREMENT	1,696	4,876	25,596	20,720	19.1
52-81-1130	FICA/MEDICARE	2,679	8,298	45,409	37,111	18.3
52-81-1150	UNEMPLOYMENT	74	226	2,026	1,800	11.1
52-81-1160	HEALTH & LIFE INSURANCE	4,765	14,944	72,033	57,089	20.8
52-81-1161	DISABILITY INSURANCE	692	1,377	8,065	6,688	17.1
52-81-2100	LEGAL FEES			15,000	15,000	.0
52-81-2990	OTHER PROFESSIONAL FEES	10,283	21,313	100,000	78,687	21.3
52-81-3110	UTILITIES	6,163	17,163	35,300	18,137	48.6
52-81-3162	CC FEES	2,753	8,883	27,000	18,117	32.9
52-81-3820	CONTINUING EDUCATION			5,000	5,000	.0
52-81-3990	MISCELLANEOUS SERVICES	361	778	6,000	5,222	13.0
52-81-4345	MAILING SERVICE	930	4,095	15,000	10,905	27.3
52-81-4810	UNIFORMS	(85)				.0
	TOTAL WASTEWATER ADMINISTRATION	67,029	193,845	954,828	760,983	20.3
<u>WASTEWATER OPERATIONS</u>						
52-82-2400	ENGINEERING	43	91	25,000	24,909	.4
52-82-2410	DISCHARGE PERMIT FEES			1,000	1,000	.0
52-82-3173	REPAIRS & MAINTENANCE - EQUIPM			6,000	6,000	.0
52-82-3177	VEHICLE REPAIRS & MAINTENANCE			5,000	5,000	.0
52-82-3178	SYSTEM REPAIR & MAINTENANCE			24,000	24,000	.0
52-82-3200	SAMPLING/TESTING		471	500	30	94.1
52-82-3290	OTHER TREATMENT COSTS		36,911	269,000	232,089	13.7
52-82-4120	SYSTEM SUPPLIES	4,182	6,356	30,000	23,644	21.2
52-82-4520	VEHICLE FUEL	100	691	7,000	6,309	9.9
52-82-4530	VEHICLE & EQUIP AMORTIZATION	147	442	8,800	8,358	5.0
52-82-4850	UNANTICIPATED EXP/CONTINGENCY			10,000	10,000	.0
52-82-4990	MISCELLANEOUS SUPPLIES		444	2,000	1,556	22.2
	TOTAL WASTEWATER OPERATIONS	4,472	45,406	388,300	342,894	11.7
<u>WASTEWATER CAPITAL</u>						
52-83-7500	CONSTRUCTION	1,269	5,721	263,000	257,279	2.2
	TOTAL WASTEWATER CAPITAL	1,269	5,721	263,000	257,279	2.2
	TOTAL FUND EXPENDITURES	72,769	244,971	1,606,128	1,361,157	15.3
	NET REVENUE OVER EXPENDITURES	264,075	608,856	445,572	(163,284)	136.7

TOWN OF SEVERANCE
BALANCE SHEET
MARCH 31, 2026

STORMWATER FUND

ASSETS

53-100000	CASH - COMBINED FUND	2,099,168	
53-115000	ACCOUNTS RECEIVABLE	26,406	
53-162100	ACCUMULATED DEPRECIATION	(1,372,348)	
53-163000	STORM DRAINAGE SYSTEM	10,100,442	
53-164000	VEHICLES & EQUIPMENT	86,490	
	TOTAL ASSETS		10,940,158

LIABILITIES AND EQUITY

LIABILITIES

53-212000	ACCRUED COMPENSATED ABSENCES	2,979	
	TOTAL LIABILITIES		2,979

FUND EQUITY

53-273000	CONTRIBUTED CAPITAL	4,113,680	
	UNAPPROPRIATED FUND BALANCE:		
53-290000	RETAINED EARNINGS	6,712,099	
	REVENUE OVER EXPENDITURES - YTD	111,400	
	BALANCE - CURRENT DATE	6,823,499	
	TOTAL FUND EQUITY		10,937,178
	TOTAL LIABILITIES AND EQUITY		10,940,158

TOWN OF SEVERANCE
REVENUES AND EXPENDITURES WITH COMPARISON TO BUDGET
FOR THE 3 MONTHS ENDING MARCH 31, 2026

STORMWATER FUND

		PERIOD ACTUAL	YTD ACTUAL	BUDGET	UNEARNED	PCNT
REVENUE						
<u>CHARGES FOR SERVICES</u>						
53-34-1000	STORMWATER UTILITY FEE	26,037	78,017	267,400	189,383	29.2
	TOTAL CHARGES FOR SERVICES	26,037	78,017	267,400	189,383	29.2
<u>MISCELLANEOUS</u>						
53-36-3500	INTEREST AND DIVIDENDS	9,733	18,641	55,000	36,359	33.9
53-36-3550	CHANGE IN MARKET VALUE	11,899	14,786		(14,786)	.0
	TOTAL MISCELLANEOUS	21,633	33,427	55,000	21,573	60.8
	TOTAL FUND REVENUE	47,670	111,443	322,400	210,957	34.6

TOWN OF SEVERANCE
EXPENDITURES WITH COMPARISON TO BUDGET
FOR THE 3 MONTHS ENDING MARCH 31, 2026

STORMWATER FUND

EXPENDITURES	PERIOD ACTUAL	YTD ACTUAL	BUDGET	UNEXPENDED	PCNT
<u>STORMWATER OPERATIONS</u>					
53-82-3110 UTILITIES			4,600	4,600	.0
53-82-3150 TELEPHONE			1,000	1,000	.0
53-82-4520 VEHICLE FUEL	11	43	1,000	957	4.4
TOTAL STORMWATER OPERATIONS	11	43	6,600	6,557	.7
TOTAL FUND EXPENDITURES	11	43	6,600	6,557	.7
NET REVENUE OVER EXPENDITURES	47,659	111,400	315,800	204,400	35.3

TOWN OF SEVERANCE
BALANCE SHEET
MARCH 31, 2026

CAPITAL PROJECTS

ASSETS

75-100000	CASH – COMBINED FUND	(1,908,199)	
	TOTAL ASSETS		(1,908,199)

LIABILITIES AND EQUITY

LIABILITIES

75-202000	ACCOUNTS PAYABLE	262,211	
75-205000	RETAINAGE PAYABLE	15,061	
	TOTAL LIABILITIES		277,272

FUND EQUITY

UNAPPROPRIATED FUND BALANCE:			
75-290000	FUND BALANCE	(1,008,073)	
	REVENUE OVER EXPENDITURES - YTD	(1,177,398)	
	BALANCE - CURRENT DATE	(2,185,471)	
	TOTAL FUND EQUITY		(2,185,471)
	TOTAL LIABILITIES AND EQUITY		(1,908,199)

TOWN OF SEVERANCE
EXPENDITURES WITH COMPARISON TO BUDGET
FOR THE 3 MONTHS ENDING MARCH 31, 2026

CAPITAL PROJECTS

		PERIOD ACTUAL	YTD ACTUAL	BUDGET	UNEXPENDED	PCNT
EXPENDITURES						
<u>GENERAL FUND</u>						
75-75-2400	ENGINEERING	11,835	73,253	260,000	186,747	28.2
75-75-5570	CONSERVATION		1,150	200,000	198,850	.6
75-75-7000	CAPITAL OUTLAY	455,409	531,670	2,207,430	1,675,760	24.1
75-75-7500	CONSTRUCTION	164,079	559,149	15,388,206	14,829,057	3.6
	TOTAL GENERAL FUND	631,324	1,165,223	18,055,636	16,890,413	6.5
<u>TRANSPORTATION FUND</u>						
75-77-7500	CONSTRUCTION	10,263	12,175	767,950	755,775	1.6
	TOTAL TRANSPORTATION FUND	10,263	12,175	767,950	755,775	1.6
<u>PUBLIC FACILITIES FUND</u>						
75-79-5570	CONSERVATION			750	750	.0
75-79-7000	CAPITAL OUTLAY			15,000	15,000	.0
	TOTAL PUBLIC FACILITIES FUND			15,750	15,750	.0
	TOTAL FUND EXPENDITURES	641,587	1,177,398	18,839,336	17,661,938	6.3
	NET REVENUE OVER EXPENDITURES	(641,587)	(1,177,398)	(18,839,336)	(17,661,938)	(6.3)

TOWN OF SEVERANCE
BALANCE SHEET
MARCH 31, 2026

GENERAL FIXED ASSET GROUP

<u>ASSETS</u>			
80-160000	CONSTRUCTION IN PROGRESS	3,851,393	
80-161000	LAND	1,063,770	
80-162000	BUILDINGS	3,977,268	
80-163000	IMPROVEMENTS OTHER THAN BUILDI	45,411,451	
80-164000	MACHINERY AND EQUIPMENT	1,469,305	
80-165000	VEHICLES	1,943,783	
80-169999	ACCUMULATED DEPRECIATION	(11,045,954)	
	TOTAL ASSETS		<u><u>46,671,016</u></u>
<u>LIABILITIES AND EQUITY</u>			
<u>FUND EQUITY</u>			
80-280000	INVESTMENTS IN FIXED ASSETS	46,671,016	
	TOTAL FUND EQUITY		<u><u>46,671,016</u></u>
	TOTAL LIABILITIES AND EQUITY		<u><u>46,671,016</u></u>

TOWN OF SEVERANCE
BALANCE SHEET
MARCH 31, 2026

GENERAL LONG-TERM DEBT GROUP

<u>ASSETS</u>			
90-170000	AMOUNT TO BE PROVIDED	129,904	
	TOTAL ASSETS		129,904
<u>LIABILITIES AND EQUITY</u>			
<u>LIABILITIES</u>			
90-250000	ACCRUED LEAVE	129,904	
	TOTAL LIABILITIES		129,904
	TOTAL LIABILITIES AND EQUITY		129,904

**TOWN OF SEVERANCE
PAYABLES
03/01/2026-03/31/2026**

Check Issue Date	Check Number	Payee	Amount Paid
3/2/2026	3012601	UNUM Life Insurance Co America	\$ 5,333.71
3/4/2026	11808	Ascent Broadband, LLC	\$ 150.00
3/4/2026	11809	Carson Repair LLC	\$ 3,503.55
3/4/2026	11810	Contech Engineered Solutions, LLC	\$ 1,072.46
3/4/2026	11811	Fleet Upfitting Services Elite, LLC	\$ 394.20
3/4/2026	11812	Front Range Compliance Services, LLC	\$ 108.95
3/4/2026	11813	Frontier Business Products	\$ 299.45
3/4/2026	11814	La Salle Oil Co.	\$ 1,676.77
3/4/2026	11815	LightGig Communications, LLC	\$ 120.00
3/4/2026	11816	MAC Equipment, Inc.	\$ 42,947.56
3/4/2026	11817	Metro City Attorney Association	\$ 180.00
3/4/2026	11818	Morton Electric, Inc.	\$ 196,304.29
3/4/2026	11819	Next Step Communications, LLC	\$ 250.00
3/4/2026	11820	North Poudre Irrigation Co.	\$ 15,400.00
3/4/2026	11821	Senergy Petroleum, LLC	\$ 2,417.74
3/4/2026	11822	Tischler Bise, Inc.	\$ 4,384.50
3/4/2026	11823	Traffic Signal Controls Inc	\$ 2,920.00
3/4/2026	11824	University Auto Parts, Inc.	\$ 56.99
3/4/2026	11825	Upper Case Printing Ink	\$ 321.87
3/4/2026	3042601	Connecting Point Greeley	\$ 541.00
3/4/2026	3042602	Connecting Point Greeley	\$ 400.00
3/4/2026	3042610	Ayres Associates Inc.	\$ 232,676.58
3/4/2026	3042611	Colorado Civil Group Inc.	\$ 37,368.40
3/6/2026	3062601	CEBT	\$ 50,546.09
3/9/2026	3092601	Verizon Wireless	\$ 3,169.68
3/11/2026	11827	ACP INTERNATIONAL, INC	\$ 730.95
3/11/2026	11828	AED Authority	\$ 4,655.00
3/11/2026	11829	Amazon Capital Services	\$ 29.99
3/11/2026	11830	Anticimex Inc	\$ 92.00
3/11/2026	11831	Ausmus Law Firm PC	\$ 850.00
3/11/2026	11832	Carson Repair LLC	\$ 5,331.34
3/11/2026	11833	City of Longmont	\$ 800.00
3/11/2026	11834	CivicPlus	\$ 11,235.09
3/11/2026	11835	Direct Landscape Supply LLC	\$ 2,070.65
3/11/2026	11836	Douglas County Sheriff	\$ 1,500.00
3/11/2026	11837	ESS Inc.	\$ 131.10
3/11/2026	11838	Language Line Services, Inc.	\$ 91.05
3/11/2026	11839	MAC Equipment, Inc.	\$ 82.72
3/11/2026	11840	North Weld County Water District	\$ 45,474.12
3/11/2026	11841	Quench USA, Inc.	\$ 164.88
3/11/2026	11842	Ramey Environmental Compliance, Inc.,	\$ 10,713.75
3/11/2026	11843	SAFEbuilt Colorado, Inc.	\$ 11,908.24
3/11/2026	11844	Sign Solutions USA	\$ 6,275.79
3/11/2026	11845	Timber Line Electric & Control Corp	\$ 265.00

**TOWN OF SEVERANCE
PAYABLES
03/01/2026-03/31/2026**

Check Issue Date	Check Number	Payee	Amount Paid
3/11/2026	11846	Treatment Technology, LLC	\$ 524.90
3/11/2026	11847	Tri-Tech Security, Inc.	\$ 87.00
3/11/2026	11848	Utility Notification Center	\$ 533.45
3/11/2026	11849	Valley Fire Extinguisher Inc.	\$ 235.00
3/11/2026	11850	Weld County Health Department	\$ 941.00
3/11/2026	11851	Western States Land Services LLC	\$ 1,467.25
3/11/2026	3102610	Adam B Stephens	\$ 800.00
3/11/2026	3102611	Ayres Associates Inc.	\$ 5,852.50
3/18/2026	11852	Amazon Capital Services	\$ 1,693.43
3/18/2026	11853	ANGEL LIGHT PYROTECHNICS, LLC	\$ 15,000.00
3/18/2026	11854	Bison Ridge Construction, LLC	\$ 3,500.00
3/18/2026	11855	Carson Repair LLC	\$ 6,783.24
3/18/2026	11856	EAS Tire & Auto LLC	\$ 2,241.24
3/18/2026	11857	Ferguson Waterworks #1116	\$ 10,238.80
3/18/2026	11858	Freedom Mailing Services Inc	\$ 1,860.65
3/18/2026	11859	JR Engineering, LLC	\$ 1,730.00
3/18/2026	11860	La Salle Oil Co.	\$ 2,068.50
3/18/2026	11861	Martin Marietta Materials Inc.	\$ 31,807.40
3/18/2026	11862	Severance High School	\$ 1,000.00
3/18/2026	11863	Severance Storage	\$ 645.00
3/18/2026	11864	Sherwin-Williams Co	\$ 153.88
3/18/2026	11865	Treatment Technology, LLC	\$ 1,124.80
3/18/2026	11866	Weld RE 4 School District	\$ 11,664.00
3/18/2026	11867	Windsor-Severance Fire Dist.	\$ 2,772.00
3/18/2026	11889	J-U-B ENGINEERS, Inc.	\$ 3,207.20
3/18/2026	3182610	SBS Services Group LLC	\$ 1,160.00
3/18/2026	3182611	WestWater Research LLC	\$ 330.00
3/19/2026	3192601	Mountain High Disposal	\$ 45.00
3/20/2026	3202601	Connecting Point Greeley	\$ 11,043.10
3/20/2026	3202602	Pitney Bowes Inc.	\$ 91.29
3/20/2026	3202603	Republic Services, Inc	\$ 47.28
3/20/2026	3202604	Town of Windsor	\$ 17,608.80
3/20/2026	3202605	Poudre Valley REA	\$ 5,434.15
3/20/2026	3202606	Xcel Energy	\$ 4,062.65
3/23/2026	3232601	Xcel Energy	\$ 9,813.56
3/23/2026	3232602	Xcel Energy	\$ 44.17
3/24/2026	3242601	Comcast	\$ 264.97
3/24/2026	3242602	Xcel Energy	\$ 2,546.02
3/25/2026	11906	Amazon Capital Services	\$ 457.45
3/25/2026	11907	Carson Repair LLC	\$ 565.76
3/25/2026	11908	Collins Control & Electric, Inc.	\$ 363.89
3/25/2026	11909	EAS Tire & Auto LLC	\$ 10,010.66
3/25/2026	11910	ECI Site Construction Manageme, Inc.	\$ 226,883.81
3/25/2026	11911	FASTSINGS DTC	\$ 90.29

**TOWN OF SEVERANCE
PAYABLES
03/01/2026-03/31/2026**

Check Issue Date	Check Number	Payee	Amount Paid
3/25/2026	11912	Frontier Business Products	\$ 131.06
3/25/2026	11913	Greeley Lock & Key	\$ 1,261.62
3/25/2026	11914	Indigo Water Group, LLC	\$ 1,100.00
3/25/2026	11915	Kinsco	\$ 306.00
3/25/2026	11916	Next Step Communications, LLC	\$ 250.00
3/25/2026	11917	Schweizer Emblem Co.	\$ 207.00
3/25/2026	11918	Security Central, Inc.	\$ 363.12
3/25/2026	11919	Treatment Technology, LLC	\$ 1,649.70
3/25/2026	11920	Upper Case Printing Ink	\$ 5,756.17
3/25/2026	11921	Weld Co Underground Water User	\$ 1,050.00
3/25/2026	3252601	Pitney Bowes Inc.	\$ 133.78
3/25/2026	3252602	ELAN Corporate Payment Systems	\$ 34,754.46
3/25/2026	3252610	Ayres Associates Inc.	\$ 109,214.69
3/25/2026	3252611	Caselle, Inc.	\$ 2,829.00
3/25/2026	3252612	Colorado Civil Group Inc.	\$ 42,399.80
3/27/2026	3272601	Comcast	\$ 1,710.58
3/27/2026	3272602	Waste Management of Colorado, Inc	\$ 456.16
3/27/2026	3272603	Waste Management of Colorado, Inc	\$ 201.70
Total:			\$ 1,307,514.39



Planning Department

March 2026 Department Update

The Planning Department continues to review several development applications across Town. Below is a summary of projects currently under review.

- **Northgate Lake (Final Plat):** 315 acres north of Harmony Road and east of CR 21, proposing 600 single-family homes with future mixed uses and open space.
- **WinDance (Preliminary Plat):** 168 acres north of Highway 392, proposing approximately 569 single-family homes and 34 acres of open space.
- **Platte Valley Veterinary Clinic (Site Plan):** Proposed two-story, 7,856-sq-ft clinic at 335 W. 4th Ave.
- **Saddle Ridge Tracts 9 & 10 (Final Plat):** 11 acres north of SH 14, proposing paired homes and single-family lots.
- **Schlagel Minor Subdivision:** Four rural residential lots west of CR 21.
- **Saddler Southern (Preliminary Plat):** 46 acres proposing single-family homes and commercial space.
- **Berrado Holdings (Minor Subdivision):** 20-acre lot for an existing PRPA electrical substation.
- **Bower North (Preliminary Plat):** 160 acres south of Hunters Crossing and west of CR 19, proposing 31 large residential lots, 278 single family, 5-acre commercial area and open space.

Several of these projects will move forward to public hearings before the Planning Commission and Town Council.

MAJOR INCIDENT TYPE	# INCIDENTS			
	Jan	Feb	March	YTD 2026
Fires	8	13	9	30
Hazardous Situation	26	24	26	76
Law Enforment Support	4	6	3	13
Medical	250	233	246	729
No Emergency	89	69	101	259
Public Service	77	60	81	218
Rescue	1	1	1	3
TOTAL	455	406	467	1328
Mutual Aid/Auto Aid Given	4	4	12	20
Mutual Aid/Auto Aid Received	7	8	0	15

The National Emergency Response Information System (NERIS) uses these 7 categories to track emergency response incidents nationally.

of Incidents by Month: 2026 vs 2025 & 2024

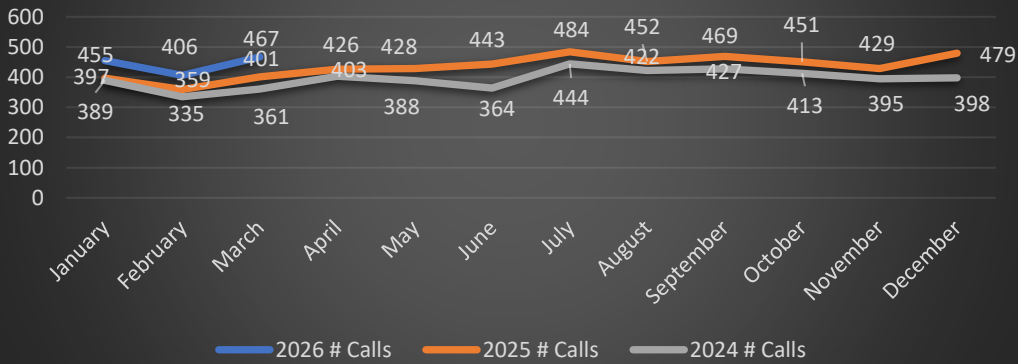

This chart illustrates the calls for service by month relative to the past years.

Incidents per Station - March 2026

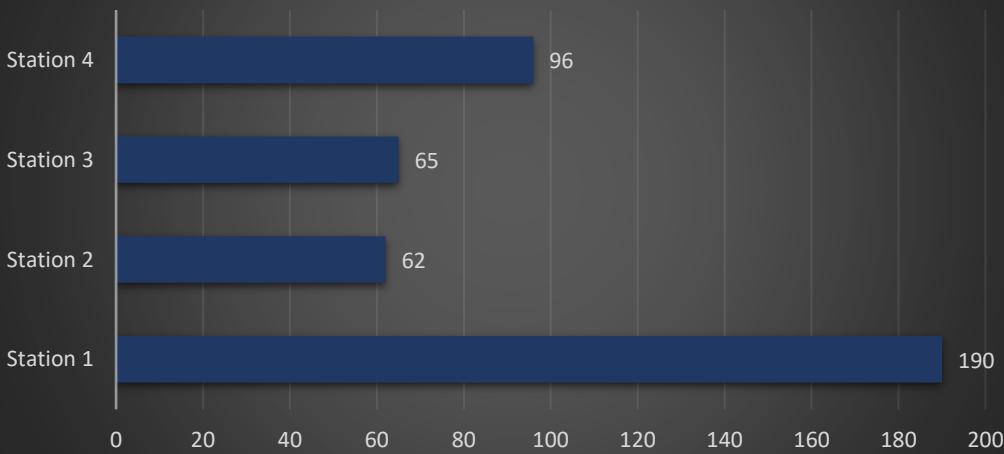

WSFR tracks incidents by the location of the incident based on which station is the closest.



WSFR Response Report: April 2026



EMS Response Times - 90th Percentile for February 2026

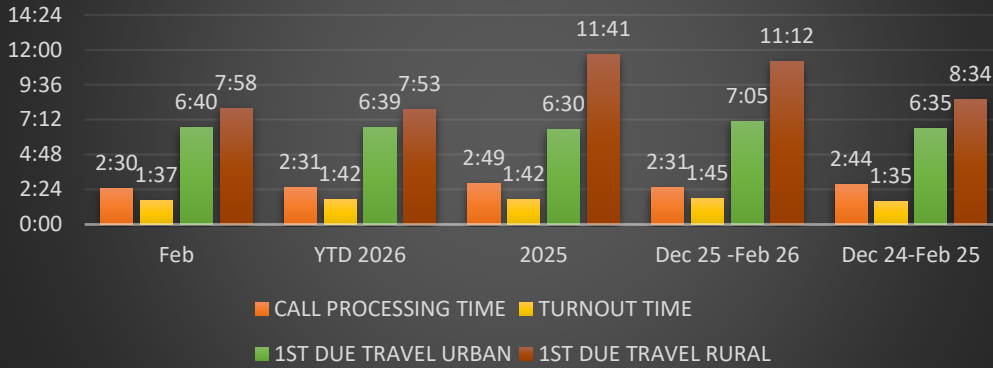

MVA Response Times - 90th Percentile for February 2026

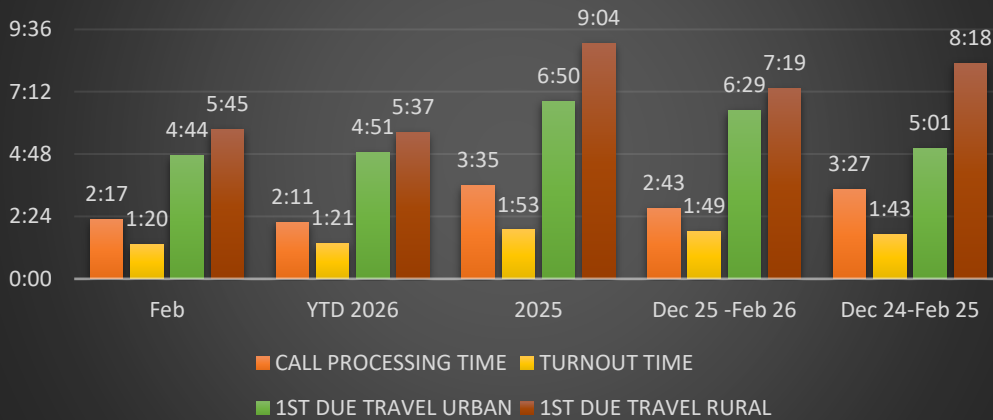

Fire, Wildland, Hazmat and Technical Rescue Response Times - 90th Percentile for February 2026

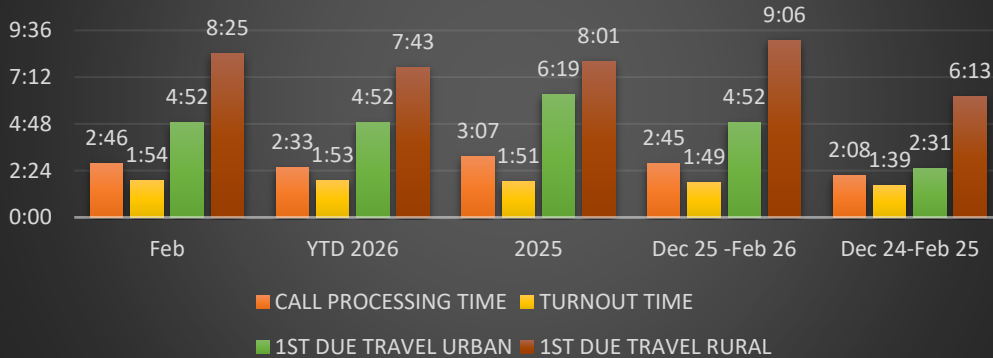

These graphs are looking at the average (90th percentile) for the following 3 segments: Call Processing times (911 answering), Turnout Times (time it takes WSFR/UCH units to begin to respond), and 1st Due Travel (time it takes for the first arriving unit to travel to the incident). When added together, that is the total time for responding to incidents. WSFR also looks at our response data at the 90th percentile as a measure of greater accuracy as part of our accreditation data analysis.



WSFR Response Report: April 2026



Revenue Type Summary

Period: 3/1/2026 - 3/31/2026
Created by: DANIELLE CRAWFORD on 4/2/2026 9:38:26 AM

Severance Court Clerk
Severance Municipal Court
3 S. Timber Ridge Parkway
Severance, CO. 80550

Payment Amounts by Type

Type	Amount
COURT COSTS	\$560.00
FINES	\$10,315.00
RESTITUTION	\$220.00
SUR-CHARGE	\$1,580.00
Payments Total	\$12,675.00

Payment Amounts by Subtype

Revenue Summary

Period: 3/1/2026 - 3/31/2026
Created by: DANIELLE CRAWFORD on 4/2/2026 9:35:50 AM

Severance Court Clerk
Severance Municipal Court
3 S. Timber Ridge Parkway
Severance, CO. 80550

Docket # D3654	Total Fines \$200.00	Restitution \$0.00	Total Payments \$200.00
--------------------------	--------------------------------	------------------------------	-----------------------------------

Payment Details

Date	Amount	Type	Notes
3/5/2026	\$200.00	CREDIT CARD	

Fines/Fees Details

Fine/Fee	Amount
COURT COSTS	\$30.00
FINES	\$150.00
SUR-CHARGE	\$20.00

Docket # D260014	Total Fines \$350.00	Restitution \$0.00	Total Payments \$20.00
----------------------------	--------------------------------	------------------------------	----------------------------------

Payment Details

Date	Amount	Type	Notes
3/5/2026	\$20.00	CREDIT CARD	

Fines/Fees Details

Fine/Fee	Amount
COURT COSTS	\$30.00
FINES	\$300.00
SUR-CHARGE	\$20.00

Docket # D3454	Total Fines \$170.00	Restitution \$0.00	Total Payments \$170.00
--------------------------	--------------------------------	------------------------------	-----------------------------------

Payment Details

Date	Amount	Type	Notes
3/29/2026	\$170.00	CREDIT CARD	

Fines/Fees Details

Fine/Fee	Amount
FINES	\$150.00
SUR-CHARGE	\$20.00

Docket # D3269	Total Fines \$350.00	Restitution \$220.00	Total Payments \$220.00
--------------------------	--------------------------------	--------------------------------	-----------------------------------

Payment Details

Date	Amount	Type	Notes
3/5/2026	\$220.00	CREDIT CARD	

Fines/Fees Details

Fine/Fee	Amount
COURT COSTS	\$30.00
FINES	\$300.00
RESTITUTION	\$220.00
SUR-CHARGE	\$20.00

Docket # D3622	Total Fines \$200.00	Restitution \$0.00	Total Payments \$200.00
--------------------------	--------------------------------	------------------------------	-----------------------------------

Payment Details

Date	Amount	Type	Notes
3/5/2026	\$200.00	CREDIT CARD	

Fines/Fees Details

Fine/Fee	Amount
COURT COSTS	\$30.00
FINES	\$150.00
SUR-CHARGE	\$20.00

Docket # D2600038	Total Fines \$70.00	Restitution \$0.00	Total Payments \$70.00
-----------------------------	-------------------------------	------------------------------	----------------------------------

Payment Details

Date	Amount	Type	Notes
3/4/2026	\$70.00	CREDIT CARD	

Fines/Fees Details

Fine/Fee	Amount
FINES	\$50.00
SUR-CHARGE	\$20.00

Docket # D2600101	Total Fines \$170.00	Restitution \$0.00	Total Payments \$170.00
-----------------------------	--------------------------------	------------------------------	-----------------------------------

Payment Details

Date	Amount	Type	Notes
3/10/2026	\$170.00	CREDIT CARD	

Fines/Fees Details

Fine/Fee	Amount
FINES	\$150.00
SUR-CHARGE	\$20.00

Docket # D100464	Total Fines \$70.00	Restitution \$0.00	Total Payments \$70.00
----------------------------	-------------------------------	------------------------------	----------------------------------

Payment Details

Date	Amount	Type	Notes
3/16/2026	\$70.00	CREDIT CARD	

Fines/Fees Details

Fine/Fee	Amount
FINES	\$50.00
SUR-CHARGE	\$20.00

Docket # D3623	Total Fines \$200.00	Restitution \$0.00	Total Payments \$200.00
--------------------------	--------------------------------	------------------------------	-----------------------------------

Payment Details

Date	Amount	Type	Notes
3/5/2026	\$200.00	CASH	

Fines/Fees Details

Fine/Fee	Amount
COURT COSTS	\$30.00
FINES	\$150.00
SUR-CHARGE	\$20.00

Docket # D2600069	Total Fines \$200.00	Restitution \$0.00	Total Payments \$200.00
-----------------------------	--------------------------------	------------------------------	-----------------------------------

Payment Details

Date	Amount	Type	Notes
3/10/2026	\$200.00	CREDIT CARD	

Fines/Fees Details

Fine/Fee	Amount
COURT COSTS	\$30.00
FINES	\$150.00
SUR-CHARGE	\$20.00

Docket # D2600032	Total Fines \$200.00	Restitution \$0.00	Total Payments \$200.00
-----------------------------	--------------------------------	------------------------------	-----------------------------------

Payment Details

Date	Amount	Type	Notes
3/5/2026	\$200.00	CREDIT CARD	

Fines/Fees Details

Fine/Fee	Amount
COURT COSTS	\$30.00
FINES	\$150.00
SUR-CHARGE	\$20.00

Docket # D3274	Total Fines \$75.00	Restitution \$0.00	Total Payments \$75.00
--------------------------	-------------------------------	------------------------------	----------------------------------

Payment Details

Date	Amount	Type	Notes
3/5/2026	\$75.00	CREDIT CARD	

Fines/Fees Details

Fine/Fee	Amount
COURT COSTS	\$30.00
FINES	\$25.00
SUR-CHARGE	\$20.00

Docket # D3666	Total Fines \$170.00	Restitution \$0.00	Total Payments \$170.00
--------------------------	--------------------------------	------------------------------	-----------------------------------

Payment Details

Date	Amount	Type	Notes
3/22/2026	\$170.00	CREDIT CARD	

Fines/Fees Details

Fine/Fee	Amount
COURT COSTS	\$30.00
FINES	\$120.00
SUR-CHARGE	\$20.00

Docket # D3700	Total Fines \$170.00	Restitution \$0.00	Total Payments \$170.00
--------------------------	--------------------------------	------------------------------	-----------------------------------

Payment Details

Date	Amount	Type	Notes
3/27/2026	\$170.00	CREDIT CARD	

Fines/Fees Details

Fine/Fee	Amount
FINES	\$150.00
SUR-CHARGE	\$20.00

Docket # D2500330	Total Fines \$75.00	Restitution \$0.00	Total Payments \$75.00
-----------------------------	-------------------------------	------------------------------	----------------------------------

Payment Details

Date	Amount	Type	Notes
3/2/2026	\$75.00	CASH	

Fines/Fees Details

Fine/Fee	Amount
COURT COSTS	\$30.00
FINES	\$25.00
SUR-CHARGE	\$20.00

Docket # D2600086	Total Fines \$170.00	Restitution \$0.00	Total Payments \$170.00
-----------------------------	--------------------------------	------------------------------	-----------------------------------

Payment Details

Date	Amount	Type	Notes
3/31/2026	\$170.00	CHECK (#3167)	

Fines/Fees Details

Fine/Fee	Amount
FINES	\$150.00
SUR-CHARGE	\$20.00

Docket # D2600081	Total Fines \$70.00	Restitution \$0.00	Total Payments \$70.00
-----------------------------	-------------------------------	------------------------------	----------------------------------

Payment Details

Date	Amount	Type	Notes
3/9/2026	\$70.00	CREDIT CARD	

Fines/Fees Details

Fine/Fee	Amount
FINES	\$50.00
SUR-CHARGE	\$20.00

Docket # D100457	Total Fines \$100.00	Restitution \$0.00	Total Payments \$100.00
----------------------------	--------------------------------	------------------------------	-----------------------------------

Payment Details

Date	Amount	Type	Notes
3/12/2026	\$100.00	CASH	

Fines/Fees Details

Fine/Fee	Amount
COURT COSTS	\$30.00
FINES	\$50.00
SUR-CHARGE	\$20.00

Docket # D2600003	Total Fines \$350.00	Restitution \$0.00	Total Payments \$350.00
-----------------------------	--------------------------------	------------------------------	-----------------------------------

Payment Details

Date	Amount	Type	Notes
3/5/2026	\$350.00	CASH	

Fines/Fees Details

Fine/Fee	Amount
COURT COSTS	\$30.00
FINES	\$300.00
SUR-CHARGE	\$20.00

Docket # D3502	Total Fines \$70.00	Restitution \$0.00	Total Payments \$70.00
--------------------------	-------------------------------	------------------------------	----------------------------------

Payment Details

Date	Amount	Type	Notes
3/30/2026	\$70.00	CREDIT CARD	

Fines/Fees Details

Fine/Fee	Amount
FINES	\$50.00
SUR-CHARGE	\$20.00

Docket # D3605	Total Fines \$200.00	Restitution \$0.00	Total Payments \$150.00
--------------------------	--------------------------------	------------------------------	-----------------------------------

Payment Details

Date	Amount	Type	Notes
3/11/2026	\$150.00	CREDIT CARD	

Fines/Fees Details

Fine/Fee	Amount
COURT COSTS	\$30.00
FINES	\$150.00
SUR-CHARGE	\$20.00

Docket # D2600133	Total Fines \$170.00	Restitution \$0.00	Total Payments \$170.00
-----------------------------	--------------------------------	------------------------------	-----------------------------------

Payment Details

Date	Amount	Type	Notes
3/27/2026	\$170.00	CREDIT CARD	

Fines/Fees Details

Fine/Fee	Amount
FINES	\$150.00
SUR-CHARGE	\$20.00

Docket # D3711	Total Fines \$170.00	Restitution \$0.00	Total Payments \$170.00
--------------------------	--------------------------------	------------------------------	-----------------------------------

Payment Details

Date	Amount	Type	Notes
3/20/2026	\$170.00	CREDIT CARD	

Fines/Fees Details

Fine/Fee	Amount
FINES	\$150.00
SUR-CHARGE	\$20.00

Docket # D100604	Total Fines \$70.00	Restitution \$0.00	Total Payments \$70.00
----------------------------	-------------------------------	------------------------------	----------------------------------

Payment Details

Date	Amount	Type	Notes
3/3/2026	\$70.00	CREDIT CARD	

Fines/Fees Details

Fine/Fee	Amount
FINES	\$50.00
SUR-CHARGE	\$20.00

Docket # D2600098	Total Fines \$170.00	Restitution \$0.00	Total Payments \$170.00
-----------------------------	--------------------------------	------------------------------	-----------------------------------

Payment Details

Date	Amount	Type	Notes
3/16/2026	\$170.00	CREDIT CARD	

Fines/Fees Details

Fine/Fee	Amount
FINES	\$150.00
SUR-CHARGE	\$20.00

Docket # D3694	Total Fines \$170.00	Restitution \$0.00	Total Payments \$170.00
--------------------------	--------------------------------	------------------------------	-----------------------------------

Payment Details

Date	Amount	Type	Notes
3/16/2026	\$170.00	CREDIT CARD	

Fines/Fees Details

Fine/Fee	Amount
FINES	\$150.00
SUR-CHARGE	\$20.00

Docket # D3712	Total Fines \$170.00	Restitution \$0.00	Total Payments \$170.00
--------------------------	--------------------------------	------------------------------	-----------------------------------

Payment Details

Date	Amount	Type	Notes
3/27/2026	\$170.00	CREDIT CARD	

Fines/Fees Details

Fine/Fee	Amount
FINES	\$150.00
SUR-CHARGE	\$20.00

Docket # D2600136	Total Fines \$170.00	Restitution \$0.00	Total Payments \$170.00
-----------------------------	--------------------------------	------------------------------	-----------------------------------

Payment Details

Date	Amount	Type	Notes
3/30/2026	\$170.00	CREDIT CARD	

Fines/Fees Details

Fine/Fee	Amount
FINES	\$150.00
SUR-CHARGE	\$20.00

Docket # D2600131	Total Fines \$170.00	Restitution \$0.00	Total Payments \$170.00
-----------------------------	--------------------------------	------------------------------	-----------------------------------

Payment Details

Date	Amount	Type	Notes
3/27/2026	\$170.00	CREDIT CARD	

Fines/Fees Details

Fine/Fee	Amount
FINES	\$150.00
SUR-CHARGE	\$20.00

Docket # D3731	Total Fines \$170.00	Restitution \$0.00	Total Payments \$170.00
--------------------------	--------------------------------	------------------------------	-----------------------------------

Payment Details

Date	Amount	Type	Notes
3/30/2026	\$170.00	CASH	

Fines/Fees Details

Fine/Fee	Amount
FINES	\$150.00
SUR-CHARGE	\$20.00

Docket # D3614	Total Fines \$170.00	Restitution \$0.00	Total Payments \$170.00
--------------------------	--------------------------------	------------------------------	-----------------------------------

Payment Details

Date	Amount	Type	Notes
3/1/2026	\$170.00	CREDIT CARD	

Fines/Fees Details

Fine/Fee	Amount
FINES	\$150.00
SUR-CHARGE	\$20.00

Docket # D3691	Total Fines \$170.00	Restitution \$0.00	Total Payments \$170.00
--------------------------	--------------------------------	------------------------------	-----------------------------------

Payment Details

Date	Amount	Type	Notes
3/12/2026	\$170.00	CREDIT CARD	

Fines/Fees Details

Fine/Fee	Amount
FINES	\$150.00
SUR-CHARGE	\$20.00

Docket # D3453	Total Fines \$170.00	Restitution \$0.00	Total Payments \$170.00
--------------------------	--------------------------------	------------------------------	-----------------------------------

Payment Details

Date	Amount	Type	Notes
3/9/2026	\$170.00	CASH	

Fines/Fees Details

Fine/Fee	Amount
FINES	\$150.00
SUR-CHARGE	\$20.00

Docket # D3686	Total Fines \$170.00	Restitution \$0.00	Total Payments \$170.00
--------------------------	--------------------------------	------------------------------	-----------------------------------

Payment Details

Date	Amount	Type	Notes
3/17/2026	\$170.00	CREDIT CARD	

Fines/Fees Details

Fine/Fee	Amount
FINES	\$150.00
SUR-CHARGE	\$20.00

Docket # D2600100	Total Fines \$170.00	Restitution \$0.00	Total Payments \$170.00
-----------------------------	--------------------------------	------------------------------	-----------------------------------

Payment Details

Date	Amount	Type	Notes
3/17/2026	\$170.00	CREDIT CARD	

Fines/Fees Details

Fine/Fee	Amount
FINES	\$150.00
SUR-CHARGE	\$20.00

Docket # D100432	Total Fines \$120.00	Restitution \$0.00	Total Payments \$120.00
----------------------------	--------------------------------	------------------------------	-----------------------------------

Payment Details

Date	Amount	Type	Notes
3/5/2026	\$120.00	CREDIT CARD	

Fines/Fees Details

Fine/Fee	Amount
FINES	\$80.00
SUR-CHARGE	\$40.00

Docket # D3705	Total Fines \$170.00	Restitution \$0.00	Total Payments \$170.00
--------------------------	--------------------------------	------------------------------	-----------------------------------

Payment Details

Date	Amount	Type	Notes
3/25/2026	\$170.00	CREDIT CARD	

Fines/Fees Details

Fine/Fee	Amount
FINES	\$150.00
SUR-CHARGE	\$20.00

Docket # D2600104	Total Fines \$170.00	Restitution \$0.00	Total Payments \$170.00
-----------------------------	--------------------------------	------------------------------	-----------------------------------

Payment Details

Date	Amount	Type	Notes
3/9/2026	\$170.00	CHECK (#1117)	

Fines/Fees Details

Fine/Fee	Amount
FINES	\$150.00
SUR-CHARGE	\$20.00

Docket # D3699	Total Fines \$170.00	Restitution \$0.00	Total Payments \$170.00
--------------------------	--------------------------------	------------------------------	-----------------------------------

Payment Details

Date	Amount	Type	Notes
3/7/2026	\$170.00	CREDIT CARD	

Fines/Fees Details

Fine/Fee	Amount
FINES	\$150.00
SUR-CHARGE	\$20.00

Docket # D3685	Total Fines \$170.00	Restitution \$0.00	Total Payments \$170.00
--------------------------	--------------------------------	------------------------------	-----------------------------------

Payment Details

Date	Amount	Type	Notes
3/3/2026	\$170.00	CREDIT CARD	

Fines/Fees Details

Fine/Fee	Amount
FINES	\$150.00
SUR-CHARGE	\$20.00

Docket # D3657	Total Fines \$170.00	Restitution \$0.00	Total Payments \$170.00
--------------------------	--------------------------------	------------------------------	-----------------------------------

Payment Details

Date	Amount	Type	Notes
3/4/2026	\$170.00	CREDIT CARD	

Fines/Fees Details

Fine/Fee	Amount
FINES	\$150.00
SUR-CHARGE	\$20.00

Docket # D3456	Total Fines \$170.00	Restitution \$0.00	Total Payments \$170.00
--------------------------	--------------------------------	------------------------------	-----------------------------------

Payment Details

Date	Amount	Type	Notes
3/11/2026	\$170.00	CREDIT CARD	

Fines/Fees Details

Fine/Fee	Amount
FINES	\$150.00
SUR-CHARGE	\$20.00

Docket # D100556	Total Fines \$70.00	Restitution \$0.00	Total Payments \$70.00
----------------------------	-------------------------------	------------------------------	----------------------------------

Payment Details

Date	Amount	Type	Notes
3/3/2026	\$70.00	CREDIT CARD	

Fines/Fees Details

Fine/Fee	Amount
FINES	\$50.00
SUR-CHARGE	\$20.00

Docket # D2600079	Total Fines \$70.00	Restitution \$0.00	Total Payments \$70.00
-----------------------------	-------------------------------	------------------------------	----------------------------------

Payment Details

Date	Amount	Type	Notes
3/5/2026	\$70.00	CREDIT CARD	

Fines/Fees Details

Fine/Fee	Amount
FINES	\$50.00
SUR-CHARGE	\$20.00

Docket # D100474	Total Fines \$70.00	Restitution \$0.00	Total Payments \$70.00
----------------------------	-------------------------------	------------------------------	----------------------------------

Payment Details

Date	Amount	Type	Notes
3/1/2026	\$70.00	CREDIT CARD	

Fines/Fees Details

Fine/Fee	Amount
FINES	\$50.00
SUR-CHARGE	\$20.00

Docket # D2600095	Total Fines \$170.00	Restitution \$0.00	Total Payments \$170.00
-----------------------------	--------------------------------	------------------------------	-----------------------------------

Payment Details

Date	Amount	Type	Notes
3/2/2026	\$170.00	CREDIT CARD	

Fines/Fees Details

Fine/Fee	Amount
FINES	\$150.00
SUR-CHARGE	\$20.00

Docket # D2600114	Total Fines \$170.00	Restitution \$0.00	Total Payments \$170.00
-----------------------------	--------------------------------	------------------------------	-----------------------------------

Payment Details

Date	Amount	Type	Notes
3/2/2026	\$170.00	CREDIT CARD	

Fines/Fees Details

Fine/Fee	Amount
FINES	\$150.00
SUR-CHARGE	\$20.00

Docket # D3722	Total Fines \$170.00	Restitution \$0.00	Total Payments \$170.00
--------------------------	--------------------------------	------------------------------	-----------------------------------

Payment Details

Date	Amount	Type	Notes
3/27/2026	\$170.00	CREDIT CARD	

Fines/Fees Details

Fine/Fee	Amount
FINES	\$150.00
SUR-CHARGE	\$20.00

Docket # D100475	Total Fines \$70.00	Restitution \$0.00	Total Payments \$70.00
----------------------------	-------------------------------	------------------------------	----------------------------------

Payment Details

Date	Amount	Type	Notes
3/3/2026	\$70.00	CREDIT CARD	

Fines/Fees Details

Fine/Fee	Amount
FINES	\$50.00
SUR-CHARGE	\$20.00

Docket # D3714	Total Fines \$170.00	Restitution \$0.00	Total Payments \$170.00
--------------------------	--------------------------------	------------------------------	-----------------------------------

Payment Details

Date	Amount	Type	Notes
3/16/2026	\$170.00	CREDIT CARD	

Fines/Fees Details

Fine/Fee	Amount
FINES	\$150.00
SUR-CHARGE	\$20.00

Docket # D3704	Total Fines \$170.00	Restitution \$0.00	Total Payments \$170.00
--------------------------	--------------------------------	------------------------------	-----------------------------------

Payment Details

Date	Amount	Type	Notes
3/11/2026	\$170.00	CASH	

Fines/Fees Details

Fine/Fee	Amount
FINES	\$150.00
SUR-CHARGE	\$20.00

Docket # D3652	Total Fines \$200.00	Restitution \$0.00	Total Payments \$200.00
--------------------------	--------------------------------	------------------------------	-----------------------------------

Payment Details

Date	Amount	Type	Notes
3/14/2026	\$170.00	CREDIT CARD	
3/16/2026	\$30.00	CREDIT CARD	

Fines/Fees Details

Fine/Fee	Amount
COURT COSTS	\$30.00
FINES	\$150.00
SUR-CHARGE	\$20.00

Docket # D3688	Total Fines \$170.00	Restitution \$0.00	Total Payments \$170.00
--------------------------	--------------------------------	------------------------------	-----------------------------------

Payment Details

Date	Amount	Type	Notes
3/25/2026	\$170.00	CREDIT CARD	

Fines/Fees Details

Fine/Fee	Amount
FINES	\$150.00
SUR-CHARGE	\$20.00

Docket # D2600112	Total Fines \$70.00	Restitution \$0.00	Total Payments \$70.00
-----------------------------	-------------------------------	------------------------------	----------------------------------

Payment Details

Date	Amount	Type	Notes
3/5/2026	\$70.00	CREDIT CARD	

Fines/Fees Details

Fine/Fee	Amount
FINES	\$50.00
SUR-CHARGE	\$20.00

Docket # D2600042	Total Fines \$200.00	Restitution \$0.00	Total Payments \$200.00
-----------------------------	--------------------------------	------------------------------	-----------------------------------

Payment Details

Date	Amount	Type	Notes
3/5/2026	\$200.00		

Fines/Fees Details

Fine/Fee	Amount
COURT COSTS	\$30.00
FINES	\$150.00
SUR-CHARGE	\$20.00

Docket # D3726	Total Fines \$170.00	Restitution \$0.00	Total Payments \$170.00
--------------------------	--------------------------------	------------------------------	-----------------------------------

Payment Details

Date	Amount	Type	Notes
3/30/2026	\$170.00	CREDIT CARD	

Fines/Fees Details

Fine/Fee	Amount
FINES	\$150.00
SUR-CHARGE	\$20.00

Docket # D3458	Total Fines \$170.00	Restitution \$0.00	Total Payments \$170.00
--------------------------	--------------------------------	------------------------------	-----------------------------------

Payment Details

Date	Amount	Type	Notes
3/13/2026	\$170.00	CHECK (#9231)	

Fines/Fees Details

Fine/Fee	Amount
FINES	\$150.00
SUR-CHARGE	\$20.00

Docket # D3457	Total Fines \$170.00	Restitution \$0.00	Total Payments \$170.00
--------------------------	--------------------------------	------------------------------	-----------------------------------

Payment Details

Date	Amount	Type	Notes
3/3/2026	\$170.00	CHECK (#3457)	

Fines/Fees Details

Fine/Fee	Amount
FINES	\$150.00
SUR-CHARGE	\$20.00

Docket # D3460	Total Fines \$170.00	Restitution \$0.00	Total Payments \$170.00
--------------------------	--------------------------------	------------------------------	-----------------------------------

Payment Details

Date	Amount	Type	Notes
3/19/2026	\$170.00	CREDIT CARD	

Fines/Fees Details

Fine/Fee	Amount
FINES	\$150.00
SUR-CHARGE	\$20.00

Docket # D100560	Total Fines \$70.00	Restitution \$0.00	Total Payments \$70.00
----------------------------	-------------------------------	------------------------------	----------------------------------

Payment Details

Date	Amount	Type	Notes
3/5/2026	\$70.00	CREDIT CARD	

Fines/Fees Details

Fine/Fee	Amount
FINES	\$50.00
SUR-CHARGE	\$20.00

Docket # D2500372	Total Fines \$170.00	Restitution \$0.00	Total Payments \$70.00
-----------------------------	--------------------------------	------------------------------	----------------------------------

Payment Details

Date	Amount	Type	Notes
3/6/2026	\$70.00	CHECK (#141)	

Fines/Fees Details

Fine/Fee	Amount
COURT COSTS	\$30.00
FINES	\$120.00
SUR-CHARGE	\$20.00

Docket # D2500426	Total Fines \$200.00	Restitution \$0.00	Total Payments \$200.00
-----------------------------	--------------------------------	------------------------------	-----------------------------------

Payment Details

Date	Amount	Type	Notes
3/27/2026	\$200.00	CREDIT CARD	

Fines/Fees Details

Fine/Fee	Amount
COURT COSTS	\$30.00
FINES	\$150.00
SUR-CHARGE	\$20.00

Docket # D3629	Total Fines \$75.00	Restitution \$0.00	Total Payments \$75.00
--------------------------	-------------------------------	------------------------------	----------------------------------

Payment Details

Date	Amount	Type	Notes
3/5/2026	\$75.00	CASH	

Fines/Fees Details

Fine/Fee	Amount
COURT COSTS	\$30.00
FINES	\$25.00
SUR-CHARGE	\$20.00

Docket # D3665	Total Fines \$350.00	Restitution \$0.00	Total Payments \$350.00
--------------------------	--------------------------------	------------------------------	-----------------------------------

Payment Details

Date	Amount	Type	Notes
3/5/2026	\$350.00	CASH	

Fines/Fees Details

Fine/Fee	Amount
COURT COSTS	\$30.00
FINES	\$300.00
SUR-CHARGE	\$20.00

Docket # D3455	Total Fines \$170.00	Restitution \$0.00	Total Payments \$170.00
--------------------------	--------------------------------	------------------------------	-----------------------------------

Payment Details

Date	Amount	Type	Notes
3/18/2026	\$170.00	CREDIT CARD	

Fines/Fees Details

Fine/Fee	Amount
FINES	\$150.00
SUR-CHARGE	\$20.00

Docket # D3238	Total Fines \$170.00	Restitution \$0.00	Total Payments \$170.00
--------------------------	--------------------------------	------------------------------	-----------------------------------

Payment Details

Date	Amount	Type	Notes
3/4/2026	\$170.00	CREDIT CARD	

Fines/Fees Details

Fine/Fee	Amount
FINES	\$150.00
SUR-CHARGE	\$20.00

Docket # D2600132	Total Fines \$170.00	Restitution \$0.00	Total Payments \$170.00
-----------------------------	--------------------------------	------------------------------	-----------------------------------

Payment Details

Date	Amount	Type	Notes
3/27/2026	\$170.00	CREDIT CARD	

Fines/Fees Details

Fine/Fee	Amount
FINES	\$150.00
SUR-CHARGE	\$20.00

Docket # D3695	Total Fines \$170.00	Restitution \$0.00	Total Payments \$170.00
--------------------------	--------------------------------	------------------------------	-----------------------------------

Payment Details

Date	Amount	Type	Notes
3/28/2026	\$170.00	CREDIT CARD	

Fines/Fees Details

Fine/Fee	Amount
FINES	\$150.00
SUR-CHARGE	\$20.00

Docket # D2500316	Total Fines \$350.00	Restitution \$0.00	Total Payments \$350.00
-----------------------------	--------------------------------	------------------------------	-----------------------------------

Payment Details

Date	Amount	Type	Notes
3/4/2026	\$350.00	CASH	

Fines/Fees Details

Fine/Fee	Amount
COURT COSTS	\$30.00
FINES	\$300.00
SUR-CHARGE	\$20.00

Docket # D2500250	Total Fines \$200.00	Restitution \$0.00	Total Payments \$100.00
-----------------------------	--------------------------------	------------------------------	-----------------------------------

Payment Details

Date	Amount	Type	Notes
3/13/2026	\$100.00	CREDIT CARD	

Fines/Fees Details

Fine/Fee	Amount
COURT COSTS	\$30.00
FINES	\$150.00
SUR-CHARGE	\$20.00

Docket # D3709	Total Fines \$170.00	Restitution \$0.00	Total Payments \$170.00
--------------------------	--------------------------------	------------------------------	-----------------------------------

Payment Details

Date	Amount	Type	Notes
3/14/2026	\$170.00	CREDIT CARD	

Fines/Fees Details

Fine/Fee	Amount
FINES	\$150.00
SUR-CHARGE	\$20.00

Docket # D100025	Total Fines \$70.00	Restitution \$0.00	Total Payments \$70.00
----------------------------	-------------------------------	------------------------------	----------------------------------

Payment Details

Date	Amount	Type	Notes
3/9/2026	\$70.00	CREDIT CARD	

Fines/Fees Details

Fine/Fee	Amount
FINES	\$50.00
SUR-CHARGE	\$20.00

Docket # D3621	Total Fines \$350.00	Restitution \$0.00	Total Payments \$350.00
--------------------------	--------------------------------	------------------------------	-----------------------------------

Payment Details

Date	Amount	Type	Notes
3/5/2026	\$350.00	CHECK (#1156)	

Fines/Fees Details

Fine/Fee	Amount
COURT COSTS	\$30.00
FINES	\$300.00
SUR-CHARGE	\$20.00

Docket # D100473	Total Fines \$70.00	Restitution \$0.00	Total Payments \$70.00
----------------------------	-------------------------------	------------------------------	----------------------------------

Payment Details

Date	Amount	Type	Notes
3/8/2026	\$70.00	CREDIT CARD	

Fines/Fees Details

Fine/Fee	Amount
FINES	\$50.00
SUR-CHARGE	\$20.00

Docket # D100462	Total Fines \$70.00	Restitution \$0.00	Total Payments \$70.00
----------------------------	-------------------------------	------------------------------	----------------------------------

Payment Details

Date	Amount	Type	Notes
3/3/2026	\$70.00	CREDIT CARD	

Fines/Fees Details

Fine/Fee	Amount
FINES	\$50.00
SUR-CHARGE	\$20.00

Docket # D2600128	Total Fines \$170.00	Restitution \$0.00	Total Payments \$170.00
-----------------------------	--------------------------------	------------------------------	-----------------------------------

Payment Details

Date	Amount	Type	Notes
3/25/2026	\$170.00	CREDIT CARD	

Fines/Fees Details

Fine/Fee	Amount
FINES	\$150.00
SUR-CHARGE	\$20.00

Fines Paid by Description

Description	Amount
ADMINISTRATIVE FEE	\$0.00
BENCH WARRANT	\$0.00
COMMUNITY SERVICE	\$0.00
CONTEMPT	\$0.00
COURT COSTS	\$530.00
DEFAULT FEE	\$0.00
FINE	\$0.00
FINES	\$9,535.00
FTA/FTP FINE	\$0.00
LATE FEE	\$0.00
OJW	\$0.00
OVERPAYMENT	\$0.00
RESTITUTION	\$220.00
RESTITUTION (LOCKED)	\$0.00
RETURNED PAYMENT FEE	\$0.00
STATE ASSESSMENT	\$0.00
SUMMONS	\$0.00
SUR-CHARGE	\$1,500.00
WARNING LETTER	\$0.00
Total Fees	\$11,955.00
Over Charged Amount	\$0.00
Total Paid	\$11,785.00

Fines Paid by Pay Method

Description	Amount
CASH	\$2,010.00
CHECK	\$1,100.00
CREDIT CARD	\$8,475.00

Overpaid Cases

Case	OverPaid
------	----------



Police Chief Report

Kenneth Chavez, Chief of Police

February 2026

Projects & Updates

- The Severance Police Department is currently fully staffed by thirteen Officers, a Community Service Officer, and two Administrative Staff members.
- On February 2nd thru 6th, Sgt. John Tucker attended a class on Internal Affairs Investigations put on by the FBI Law Enforcement Executive Development Association (FBI LEEDA).
- On February 4th, Chief Chavez attended the Run Windsor Lunch event at the Hearth Restaurant & Pub in Windsor along with town management. Race Director Mandy Mullen provided an overview of past, current, and future race events that will be held in the region as well as in Severance.
- On February 18th, Chief Chavez provided a tour of the Severance Police Department building to Mead Chief of Police, Brent Newbanks. Mead is considering building a new police building and wanted to meet with Chief Chavez to see our building as well as ask questions about lessons learned from building a new PD building.
- On February 25th, Chief Chavez held a Staff Meeting to discuss the upcoming Active Shooter Full Scale Exercise at Severance Middle School on June 17th.
- On February 25th, members of the Colorado Bureau of Investigations satellite office at Windsor PD meet with Chief Chavez and supervisors to meet and discuss future joint ventures as well as support from CBI on various investigations.
- On February 26th, Chief Chavez and Sgt. Cooper Arvisais attended a After Action Review of the Officer Involved Shooting from December 9th with the Weld County Combined Communications Center Director and Communications Center Manager. The purpose was to review radio procedures that took place during this event in order to gain lessons learned.

Community Support and Relations

- Chief Chavez met with numerous key local government and law enforcement officials this month to include the following:

- Attended the monthly Active Shooter Full Scale Exercise planning committee meeting on February 9th & 23rd.
- Attended the Weld County Chiefs of Police Assoc. lunch meeting on February 18th.
- Attended the North Weld Co-Responder meeting on February 23rd.
- Attended the Weld County Communications Board Meeting on February 24th.



Severance Police Department CALLS FOR SERVICE

PLEASE NOTE THAT MONTHLY STATS MAY VARY DUE TO WHEN INFORMATION IS PROCESSED















February 2026

THIS MONTH'S TOTALS

Municipal Ordinance Citations	83
Traffic Tickets	75
Traffic Warnings Issued	154
TOTAL CALLS FOR SERVICE	639

YEAR TO DATE TOTALS

Municipal Ordinance Citations	83
Traffic Tickets	142
Traffic Warnings Issued	400
TOTAL CALLS FOR SERVICE	1410

 Homicide	0	 Burglary	0
 Aggravated Assault	0	 Motor Vehicle Theft	0
 Sex Assault	1	 Theft From Motor Vehicle	0
 Domestic Violence	1	 Fraud / ID Theft	3
 Aggravated Robbery	0	 Vandalism/ Graffiti	0
 Strongarm Robbery	0	 Shoplifting	0
 Arrests	14	 Traffic Accidents	7

IF YOU HAVE AN EMERGENCY OR NEED TO SPEAK WITH A SEVERANCE POLICE OFFICER, PLEASE CALL 911.

If you do not wish to call 911 and still need to speak with a Severance Police Officer, please call the Weld County Dispatch 970-350-9600.



TOWN OF SEVERANCE CODE ENFORCEMENT CALLS FOR SERVICE

PLEASE NOTE THAT MONTHLY STATS MAY VARY DUE TO WHEN INFORMATION IS PROCESSED

February 2026

THIS MONTH'S TOTALS

Municipal Citations	1
Municipal Warnings Issued	14
Parking Tickets	19
TOTAL CALLS FOR SERVICE	44

YEAR TO DATE TOTALS

Municipal Citations	1
Municipal Warnings Issued	62
Parking Tickets	29
TOTAL CALLS FOR SERVICE	116



Parking Violations 35



Animal Complaints 28



Animal Bites 1



Snow Removal 0



Weed Violation 0



Rubbish / Nuisance 0

To report a code violation or to speak with the Community Service Officer, please call the Weld County Dispatch 970-350-9600.

IF YOU HAVE AN EMERGENCY OR NEED TO SPEAK WITH A SEVERANCE POLICE OFFICER, PLEASE CALL 911.



Engineering Department

April 2026 Department Update

The following is an update for Town of Severance Capital Improvement Projects and miscellaneous engineering projects by Colorado Civil Group, Inc. (CCG):

E Harmony Road – WCR 19 Intersection Improvements

Comcast is moving forward with the installation of the fiber optic service at the three (3) traffic signals located along E Harmony Road. The final Request for Reimbursement was submitted to CDOT on April 15, 2026. CDOT will review the final RFR and it is hopeful that final closeout will be completed by the end of May. This project is expected to be under the approved Town of Severance budget by about \$260,000, depending on the final reimbursement amount from CDOT.

South Water Line Loop (SWLL)

Phase 1 of the SWLL is currently under construction with the Severance Community Park – Phase 5 improvements. Phase 1 of the SWLL includes a 12” PVC water line from the Tailholt Subdivision Fourth Filing to the west side of the John Law Ditch and a water service for two (2) restroom buildings. Phase 1 of the SWLL will be completed in May 2026. Phase 2 of the SWLL needs to acquire one additional water line easement (or right-of-way) across another property. Negotiations with this property owner are being handled by Town Management and are ongoing.

1ST Street (WCR 23) Water Line Replacement

CCG is currently working with Ayres Associates and the Public Works Department on the 30% construction drawing submittal package and evaluating the EPA grant requirements. Current coordination includes the geotechnical engineering report, utility locates, topographic survey, and upcoming utility potholing.

Great Western Trail (Harmony Road to WCR 23)

A Notice of Award was provided to GLH Construction, LLC on March 3, 2026. Construction started on April 13, 2026 with GLH mobilizing on site and installing erosion control measures. Current activities include grading and earthwork, with concrete work beginning on April 23, 2026. A test panel with the “glow stones” should be completed on April 23, 2026, so that interested parties and Town staff can see a sample of the trail. Ayres Associates was awarded the Construction Management, Inspection and Materials Testing services. GLH anticipates to

complete the project early, possibly by mid-June 2026. The original construction completion date is August 14, 2026.

Water System Monitoring

CCG has been working with the Public Works Department and the NWCWD staff on a weekly basis to monitor the Town's water distribution system and performance (pressure and flowrates) continuously since June 2022. The annual Average Day Demand (ADD), Maximum Day Demand (MDD), MDD Factor, Maximum Annual Delivery Volume (MAADV), and Minimum Annual Delivery Volume (MIADV) are listed below along with the capacity purchased from the NWCWD:

2023 (calendar year)

ADD (customer): 505,128 GPD

MDD (customer): 1,099,238 GPD (16-Jul-23), MDD Factor: 2.18

MDD (NWCWD): 1,097,402 GPD (12-Jul-23)

Maximum ADV (NWCWD): 198,185,000 GPY

2024 (calendar year)

ADD (customer): 558,410 GPD

MDD (customer): 1,053,251 GPD (29-Jul-24), MDD Factor: 1.89

MDD (NWCWD): 1,061,232 GPD (13-Jul-24)

Maximum ADV (NWCWD): 220,629,000

2025 (calendar year)

ADD (customer): 524,784 GPD

MDD (customer): 1,032,415 GPD (17-Aug-25), MDD Factor: 1.97

MDD (NWCWD): 1,333,000 GPD (10-Jun-25)

Maximum ADV (NWCWD): 201,018,000 GPY

CAPACITY (PURCHASED) BASED ON 1,160 ASPITs

MDD (NWCWD): 1,670,400 GPD

Maximum ADV (NWCWD): 264,480,000 GPY

Minimum ADV (NWCWD): 213,408,000 GPY – 90% of Maximum ADV (2026 – 2035)

CCG has been working with the Public Works Department and the NWCWD to make seasonal adjustments to Master Meters No. 1 and No. 2 to meet water quality requirements. The Master Meters will be adjusted for the spring/summer scenario in April 2026. A meeting to review these settings will be scheduled with the NWCWD.

Wastewater Projections

Town Management and CCG have reached out to the Town of Windsor (TOW) regarding future wastewater treatment capacity with their planned Wastewater Treatment Facility (WWTF) expansion. Additional wastewater capacity is dependent on three items; (1) Additional capacity at the TOW WWTF, (2) a new sanitary sewer interceptor from Severance South to the Town of Windsor WWTF, and (3) a Utility Plan Amendment/208 Boundary Amendment that the Town will need to prepare and submit to the North Front Range Water Quality Planning Association (NFRWQPA) for review and approval. The Town of Windsor has requested approval of a Utility Plan Amendment (UPA), which includes a 208 Boundary Adjustment. The NFRWQPA distributed a new UPA for review in February 2026, which also benefits the Town of Severance. Comments on this UPA have been provided to Town Management. The Town Managers for Severance and Windsor are negotiating the additional wastewater treatment capacity that may be available. The FIRST AMENDMENT TO THE 2003 WASTEWATER TREATMENT SERVICE AGREEMENT has been reviewed and comments were provided to Town Management on November 24, 2025. The Town of Windsor submitted a revised AGREEMENT on February 27, 2026, which is currently being reviewed.

CCG monitors the wastewater flowrates on a daily basis. Below is a summary since the Town of Windsor wastewater flowmeter was recalibrated:

2024 (calendar year)

Average wastewater flowrate: 406,552 GPD (March 1, 2024 – December 31, 2024)

Max Day wastewater flowrate: 572,000 GPD (March 17, 2024)

2025 (calendar year)

Average wastewater flowrate: 399,963 GPD (January 1, 2025 – December 31, 2025)

May Day wastewater flowrate (Severance WWTF): 238,038 GPD (November 16, 2025)

May Day wastewater flowrate (Windsor WWTF): 514,000 GPD (March 2, 2025)

May Day wastewater flowrate (Combined): 552,234 GPD (November 9, 2025)

2026 (calendar year)

Average wastewater flowrate: 412,599 GPD (January 1, 2026 – March 31, 2026)

May Day wastewater flowrate (Severance WWTF): 238,402 GPD (March 1, 2026)

May Day wastewater flowrate (Windsor WWTF): 338,000 GPD (February 8, 2026)

May Day wastewater flowrate (Combined): 553,402 GPD (March 1, 2026)

Currently, the Town of Severance has purchased 510,000 - 515,000 GPD of treatment capacity from the Town of Windsor. Since March 1, 2024, The Town of Severance has exceeded the purchased capacity on three (3) occasions, all occurring in 2024.



Public Works Director Report

WATER/WASTEWATER

Reporting – WWTP has been back online as of 4-11-2025. A list of Lead/Copper sites has been submitted and approved by the state. Ramey Environmental has taken over all state-mandated requirements.

Sampling – All water and wastewater testing is being conducted by Weld County Labs. Ramey Environmental has taken over all samples as of 8-1-2025.

Water Tanks – All three water tanks are online. New tank level sensors have been installed on the ground tanks along with new check valves. The new clay valve solenoids have been installed.

Lift Stations – Baldrige lift station had both pumps replaced and new electronics installed. All electronics will be brought above ground with VFDs to support operations and safety during confined space entries this year.

STORM WATER

- John Law Ditch, Cr23 and Cr72 ditches have been burned and cleaned.
- Street sweeping is done once a week, weather pending this time of year.
- Cr21 West drainage ditch to be cleaned this year.
- Ditch clearing between Ponderosa and Cr72 is currently taking place.
- Russian Olive trees within the ROW along Harmony have been removed.

STREETS

- The new County road signs have been ordered.
- Our mag tank sprayer conversion is almost completed.
- Fire hydrant maintenance has been completed.
- Water meter installations for the GATEWAY are ongoing.
- 70% of the concrete cross pans have been completed.



Public Works Director Report

- Gravel road dust suppressant is scheduled to start on 4-21-26.
- Locating the next 12-15 manholes to be lined in 2026.
- I'm sending 2 techs to the motor grader training in May.
- A1 chip seal has almost completed the crack seal process. The chipseal on Harmony and within Casa Loma is scheduled to start at the end of May.
- Water valve exercise is ongoing throughout the town.

PARKS

- Dog Park rehab has been completed.
- Large overhanging tree trimming is out for bid.
- Mower & small equipment maintenance has been completed.
- The new double gate at the park's shed has been completed.
- Echo counters have been installed and are functional throughout GWT.
- Additional cameras are to be added to Lake View and Blue Spruce parks.
- The new Tailholt garden sign has been ordered.

Submitted on 04-21-2026, by the Public Works Director John Zacklene.



AGENDA ITEM SUMMARY

AGENDA ITEM	SUBMITTED BY	PRESENTED BY
Pg. 98 - Clearview Library Presentation	Nicholas Wharton, Town Manager	Erica Rose, Clearview Library Director
ACTION REQUESTED		
This is a presentation and welcomes any questions from the Town Council.	<u>Presentation</u>	
BRIEF HISTORY OF ITEM		
BRIEF SUMMARY		
Library Director, Erica Rose, is providing an update to the Town Council on the Severance Library highlights and usage.		
PUBLIC SUPPORT/CONCERN		
None at this time.		
ANALYSIS AND RECOMMENDATION		
This is a presentation and welcomes any questions from the Town Council.		
MATERIALS SUBMITTED		
The following materials were submitted and included in this packet: 1. Severance Clearview Library PPT 4.28.26		



Clearview Library District

2026 Numbers and Severance Highlights



**A
N
N
U
A
L
2025**

Patrons Served

212,731



Average Monthly Card Users

6,590

Total New Cards

4,242

Total Card Holders

29,504



2024 numbers | 2025% increase

- 191,427 Patrons served **up 11%**
- 4086 new cards **up 3.8 %**
- 5,652 active cards **up 16.6%**
- 41, 935 Program attendance **up 24%**
- 380,122 Physical circulation **up 2.6%**
- 146,834 Digital circulation **up 17.5%**
- 11,553 Computer sessions **up 13%**
- 9,593 Wifi session **up 33%**
- 398,233 Website use **up 18%**

Circulation

Physical

389,907

Virtual

172,496



Windsor

286,009

Average Monthly

Severance

81,766

Active Virtual

Bookmobile

20,121

Borrowers

3,279

Total Program Attendance

52,109

Number of Programs

1,740



Room Bookings by Patrons

3,133

Windsor

2,106

Severance

1,027



Average Monthly

Computer Users

644

Average Monthly

WiFi Usage

1,062

Total Computer

Sessions

13,054

Total Website

Usage

471,518



Severance Library

- 20% of 2025 circulation
- 33% of 2025 program attendance
- 33% of 2025 room bookings
- *Note the Town of Severance is $\frac{1}{4}$ the size of Windsor





Meeting Rooms

Patron Bookings	1,027
Time Booked	30.78%



Programming

Youth & Family Programs	472
Youth & Family Attendance	16,829
Adult Programs	22
Adult Attendance	310



Physical Circulation

81,766



Door Count

51,251



Upcoming

- Summer Adventure Program
 - Kickoff June 1
- More programming and dedicated staff





AGENDA ITEM SUMMARY

AGENDA ITEM	SUBMITTED BY	PRESENTED BY
Pg. 104 - Resolution 2026-06R: A Resolution of the Town Council of the Town of Severance, Colorado, approving an Intergovernmental Agreement between the Town of Severance, Colorado, and the City of Thornton, Colorado, for an Emergency Raw Water Interconnection	Shani Porter, Planning Director	Shani Porter, Planning Director
ACTION REQUESTED		
<p>The Town Staff asks the Town Council to review the Resolution for an Intergovernmental Agreement between the Town of Severance and the City of Thornton for an Emergency Raw Water Interconnection.</p> <p>Actions that may be taken:</p> <ul style="list-style-type: none"> • Move to approve Resolution 2026-06R • Take no action and do not approve Resolution 2026-06R 		<p><u>Resolution</u> <u>Action Requested</u> <u>Attorney Approved</u></p>
BRIEF HISTORY OF ITEM		
BRIEF SUMMARY		
<p>The City of Thornton plans to install, construct, operate and maintain a water pipeline near the future Cobb Lake Treatment facility. Emergency water supply situations may occur during which the best interests of the health, safety and welfare of the Town of Severance would be served if Severance's system were connected to the pipeline in a manner that the City of Thornton could assist Severance during such an emergency.</p>		
PUBLIC SUPPORT/CONCERN		
<p>None at this time.</p>		
ANALYSIS AND RECOMMENDATION		
<p>Town Staff recommends that the Town Council review and approve Resolution 2026-06R</p>		
MATERIALS SUBMITTED		
<p>The following materials were submitted and included in this packet:</p> <ol style="list-style-type: none"> 1. 2026-07R - Res to Approve IGA for Thornton Interconnect - FINAL 2. IGA Thornton Emergency Raw Water Interconnect 4.17.26 		

**TOWN OF SEVERANCE
RESOLUTION NO. 2026-06R**

**A RESOLUTION OF THE TOWN COUNCIL OF THE TOWN OF SEVERANCE,
COLORADO, APPROVING AN INTERGOVERNMENTAL AGREEMENT BETWEEN
THE CITY OF THORNTON AND THE TOWN OF SEVERANCE FOR AN
EMERGENCY RAW WATER CONNECTION.**

WHEREAS, the Town of Severance (“The Town”) owns and operates a water system which is supplied with water from various sources for the benefit of the inhabitants of the Town; and

WHEREAS, the City of Thornton (“Thornton”) plans to install, construct, operate, and maintain a water pipeline, generally referred to as the Thornton Water Project (“the Pipeline”); and

WHEREAS, both the Town and Thornton anticipate a portion of the Pipeline will be constructed in close proximity to the Town’s water system; and

WHEREAS, emergency water supply situations may occur in the future during which the best interest of the health, safety, and welfare of the Town would be served if the Town’s water system were connected to the Pipeline (the “Interconnect”) in a manner that Thornton could assist the Town during such an emergency; and

WHEREAS, intergovernmental agreements between political subdivisions to provide any function, service, or facility, including the sharing of costs of such function, services, or facility, are specifically authorized by C.R.S. § 29-1-203(1); and

WHEREAS, Section 12.03 of the Town of Severance Home Rule Charter provides that “The Council may by resolution enter into contracts or agreements with other governmental or quasi-governmental entities.”; and

WHEREAS, in order to further strengthen the Town’s water supply in the event of a future emergency water situation, the Town Council of the Town of Severance (“Town Council”) finds it is in the Town’s best interest and desires to enter into the attached “INTERGOVERNMENTAL AGREEMENT BETWEEN THE TOWN OF SEVERANCE, COLORADO AND THE CITY OF THORNTON, COLORADO FOR AN EMERGENCY RAW WATER INTERCONNECTION” in substantially the same form as the copy attached to this resolution; and

WHEREAS, the Town Council finds and determines that the approval of the attached intergovernmental agreement promotes the safety, security, and general welfare of the inhabitants of the Town.

NOW, THEREFORE, BE IT RESOLVED BY THE TOWN COUNCIL OF THE TOWN OF SEVERANCE, COLORADO, AS FOLLOWS:

Section 1. The above recitals and findings of the Town Council are incorporated herein and made a part of this resolution.

Section 2. The “INTERGOVERNMENTAL AGREEMENT BETWEEN THE TOWN OF SEVERANCE, COLORADO AND THE CITY OF THORNTON, COLORADO FOR AN EMERGENCY RAW WATER INTERCONNECTION” is approved in substantially the same form as the copy attached hereto and made a part of this resolution.

Section 3. The Mayor is authorized to execute this agreement on the Town’s behalf.

Section 4. The Town Manager, or his designee, is authorized to negotiate and execute all documents necessary to allow for the operation and maintenance of the Interconnect, including, but not limited to, a Standard Operating Procedures agreement, provided that such documents are necessary and consistent with the terms of this agreement.

RESOLVED AND APPROVED THIS 28TH DAY OF APRIL 2026.

TOWN OF SEVERANCE, COLORADO

Matthew Fries, Mayor

ATTEST

Sarah Jacobsen, Town Clerk

INTERGOVERNMENTAL AGREEMENT BETWEEN THE TOWN OF SEVERANCE,
COLORADO AND THE CITY OF THORNTON, COLORADO FOR AN EMERGENCY RAW
WATER INTERCONNECTION

THIS INTERGOVERNMENTAL AGREEMENT ("Agreement"), is made and entered into effective this _____ day of _____, 2026 by and between the Town of Severance, a Colorado home rule municipality ("Severance"), and the City of Thornton, a Colorado home rule municipality ("Thornton"), collectively (the "Parties").

WITNESSETH:

WHEREAS, Section 18(2)(a) of Article XIV of the Colorado Constitution and Sections 29-1-201, et seq., and 29-20-105 of the Colorado Revised Statutes authorize and encourage governments to cooperate by contracting with one another for their mutual benefit; and

WHEREAS, Thornton plans to install, construct, operate and maintain a water pipeline, generally referred to as the Thornton Water Project and appurtenances thereto (the "Pipeline"); and

WHEREAS, Severance owns and operates a water system which is supplied water from various sources; and

WHEREAS, emergency water supply situations may occur during which the best interests of the health, safety and welfare of Severance would be served if Severance's system were connected to the Pipeline in a manner that Thornton could assist Severance during such an emergency; and

NOW, THEREFORE, in consideration of the foregoing and the terms, covenants, conditions and provisions hereinafter set forth and other good and valuable consideration, the receipt and adequacy of which are hereby confessed and acknowledged, the Parties hereto agree as follows:

AGREEMENT

1. Purpose. The purpose of this Agreement is to set forth the terms and conditions to allow for the installation, construction, operation and maintenance of an emergency raw water interconnection between the Pipeline and Severance's water system. All conditions contained herein are in addition to applicable state statutes, and are not intended to supersede such requirements, except as specifically provided in this Agreement.
2. Interconnect construction. Thornton shall construct and install a twelve (12) inch "T" and valve ("Interconnect") as part of the construction and installation of the Pipeline, in the form and manner as shown in Exhibit A, attached hereto and incorporated herein by reference, and shall install the interconnect at the location shown on Exhibit B, attached hereto and incorporated herein by reference.

3. Severance connection to Interconnect. Severance, at Severance's expense, shall have the right to connect its raw water system to the Interconnect in accordance with the terms herein. Severance's connection to the Interconnect shall include facilities necessary to accurately and remotely control and measure the flow of water through the Interconnect to Severance's raw water system, both on an instantaneous basis and on a totalizing basis, and to prevent backflow from Severance's raw water system through the Interconnect to the Pipeline. Thornton shall have the right to review and approve the design of the facilities connecting the Interconnect to Severance's raw water system prior to construction and operation of Severance's connection to the Interconnect. Thornton's approval shall not be unreasonably withheld. Severance shall be responsible for acquiring the necessary easements from underlying landowners to access the facilities.
4. Ownership of facilities. Thornton shall own and be responsible for all Interconnect facilities up to and including the Interconnect valve as shown on Exhibit A. Severance shall own and be responsible for the connection to the Interconnect valve and all facilities downstream of the Interconnect valve as shown on Exhibit A. Severance will purchase and convey to Thornton a meter compatible with Thornton's systems that is capable of accurately and remotely measuring the flow of water through the Interconnect.
5. Maintenance and inspection of Severance facilities. Thornton shall have the right to inspect Severance's Interconnect-related facilities at any time, and Thornton reserves the right to refuse service through the Interconnect if such facilities are not maintained in a condition to ensure accurate control and measurement of any water deliveries, and to protect Thornton's water system from backflow from Severance's water system.
6. Use of Interconnect. The Interconnect shall be used in the event of an emergency if Thornton is capable of, as defined below, providing raw water at the time of the request to activate the Interconnect. For purposes of this Agreement, an emergency is a main break, other infrastructure failure, a catastrophe, a natural disaster, or any electrical or mechanical power failure or other occurrence beyond the Town's control which causes partial or total inability of Severance's raw water system to provide adequate water for fire protection and/or domestic water service. A shortage of untreated water available to Severance's water system or pursuant to its water rights due to drought or other hydrologic conditions shall not be deemed an emergency.
7. Capable of providing raw water.
 - a. Thornton shall not be deemed capable of providing raw water for events that affect the structure, integrity or operation of the Pipeline or the source of water available to Thornton beyond its reasonable control, including but not limited to: 1) acts of God (such as, but not limited to, fires, explosions, earthquakes, drought, and floods); 2) acts of war (whether declared or not), hostilities, invasion, act of foreign enemies, terrorism or civil disorder; 3) any legal prohibition to operating the Pipeline or delivery of Thornton's source water; 4) contamination of the source water such that Thornton would not take such source water into its municipal supply; 5) loss of electrical power; 6) accident, breakage, or equipment failure causing the Pipeline to be inoperable; or 7) other unforeseeable circumstance beyond the control of Thornton and which

Thornton cannot avoid even by using its best efforts.

- b. Thornton shall not be deemed capable of providing raw water in situations where Thornton, in its sole discretion, needs one hundred percent (100%) of either the Pipeline capacity or Thornton's source water or both, for delivery of or use of its source water for its own municipal uses. If the Interconnect has been activated and Thornton does not have the Pipeline capacity or its source water available in excess of what is required to meet its own water needs, Thornton may cease deliveries and deactivate the Interconnect upon twelve (12) hours written notice to Severance.
 - c. If Severance has requested Thornton to activate the Interconnect and Thornton is not capable of providing raw water as provided in paragraph 7.a. or 7.b. above, Thornton shall notify Severance of the nature and expected duration of such event and shall thereafter keep Severance informed of the status of Thornton's capability of providing raw water. Thornton shall use all reasonable means to overcome the effects of such event and to provide raw water as soon as reasonably practicable.
 - d. Activation of Interconnect. In the event of an emergency, as defined in paragraph 6 above, Severance shall notify Thornton of its request to activate the Interconnect to deliver raw water into Severance's system. The request for activation shall be made in accordance with paragraph 19 below and by calling the phone number provided by Thornton in the Standard Operating Procedure (SOP), as defined in paragraph 8. If an emergency exists, and Thornton is capable of providing raw water, Thornton shall grant permission to allow Severance to activate the Interconnect before it receives written notice.
8. Operation of Interconnect. Severance and Thornton shall develop a Severance Emergency Raw Water Interconnect SOP for operation of the Interconnect. Among other matters, the SOP will address that minimum flows may be required depending on the situation. The Interconnect shall not be operated without a mutually agreed-upon SOP executed by Thornton's City Manager or designee (or equivalent) and Severance's Town Manager or designee (or equivalent). The Parties agree to act in good faith to develop an SOP that satisfies the intent and purposes of this Agreement. The SOP must be executed by Thornton's City Manager or designee (or equivalent) and Severance's Town Manager or designee (or equivalent) prior to Severance making a connection to the Interconnect. The Parties may amend the SOP from time to time to reflect changing conditions, personnel, or other matters referenced in the SOP.
 9. Deactivation of Interconnect. Severance shall make all reasonable efforts to resolve the emergency situation and curtail deliveries from the Interconnect as soon as possible. So long as Thornton is capable of providing raw water, Severance shall have the right to use the Interconnect for a reasonable time period to allow it to resolve the emergency situation. Severance will notify Thornton of its intent to stop delivery of water through the Interconnect as soon as is reasonably possible after such intent is known by Severance. When deliveries have ceased, Severance will close the Interconnect valve per the procedures provided in the SOP.
 10. Billing. Billing for water delivered to Severance through the Interconnect shall be at 1.25

times the then-current applicable rate Thornton charges for delivery of non-potable irrigation water (not Augmentation Water) to customers. In the event Thornton changes its water rate methodology in a manner that impacts its non-potable rates, Thornton shall advise Severance of the new rate schedule. However, additional operation and maintenance costs will be charged if Thornton must start up and operate the Pipeline to make emergency Interconnect deliveries to Severance to the extent that Pipeline is not otherwise delivering water and Thornton is capable of delivering water. Thornton shall bill Severance within sixty (60) days following delivery, and payment shall be due within thirty (30) days of the billing date.

11. Water pressure. Thornton makes no guarantee of pressure of water available through the Interconnect, and Severance understands and acknowledges that significant pressure fluctuations may occur.
12. Water quality. Thornton makes no guarantee as to the quality of the water available through the Interconnect, and Severance understands and acknowledges that significant quality fluctuations may occur. Severance further understands and acknowledges that the water delivered through the Interconnect may be of significantly different quality than Severance's other raw water sources and accepts all responsibility for the quality of water provided to its customers.
13. Liability for use of Interconnect. It is expressly understood that in the event the Interconnect is activated and to the fullest extent permitted by law, Severance agrees to indemnify and hold harmless Thornton, its officers, agents and employees against any and all liability, loss, damage, demands, actions, causes of action or expenses of whatever nature (including court costs and attorney's fees) which may result from any injuries or damage received by any person, firm, corporation or other entity, which arise out of or are caused by the delivery of raw water through the Interconnect, or in connection with Thornton's furnishing of emergency water service to Severance under this Agreement, except for such liability, loss, damage, demands, actions, causes of action or expenses which are attributable to negligent acts or omissions or willful misconduct of Thornton, its employees, agents or contractors.
14. Term. This Agreement shall be effective for a ten-year term beginning on the date of execution hereof. Upon expiration of the ten-year period, this Agreement may be renewed for an additional ten-year period if the Parties mutually agree to said renewal. Severance may terminate this Agreement at any time by providing sixty (60) days prior written notice of termination of the Agreement. Thornton may only terminate the Agreement during the initial ten-year term as provided in paragraph 15 below.
15. Termination. If either Party fails to comply with a material term of this Agreement, the non-defaulting Party may provide notice of the alleged performance failure to the other Party and the Parties shall within thirty (30) days meet and confer in good faith in an effort to agree on a resolution of the breach. If the Parties are unable to resolve the dispute despite such good faith efforts, then either Party may, at its option, commence mediation. The mediation shall occur at a location that is within fifty (50) miles of Severance, unless the Parties agree to a different location, and the cost shall be split equally between the

Parties. If the Parties are not able to resolve the dispute within sixty (60) days of the commencement of mediation, in addition to other remedies available at law, then either Party may provide ninety (90) days written notice to terminate this Agreement.

16. Use of Thornton water. All water furnished pursuant to this Agreement is on a leasehold basis for the use of Severance and its customers for all the various purposes for which Thornton has been decreed the right to appropriate water. Water delivered to Severance through the Interconnect for use by Severance and its customers is for primary use only and does not include any right to make a succession of uses of such water. Upon completion of the primary use by Severance or its customers all dominion and control over the water delivered through the Interconnect reverts completely to Thornton. Except as otherwise provided, all property rights to the water to be furnished by Thornton hereunder are reserved by Thornton, provided, however, that nothing herein shall be deemed or construed as creating an obligation on Thornton to separate said water from any material added to it in use by Severance or its customers or as creating any obligation on Thornton regarding the treatment of any wastewater generated by the use of water delivered to Severance through the Interconnect. It is mutually agreed that there is no obligation on Severance to create any particular volume of return flow from water delivered pursuant to this Agreement. Severance will cooperate with Thornton to provide any water accounting information required by the State Engineer's Office from use of the Interconnect.
17. Thornton's water rights. It is specifically acknowledged by Severance that the water to be delivered in the Pipeline is associated with Thornton's Northern Project Decree on Remand Case No. 87CW332. Thornton's water is not decreed for use in or by Severance, and any use by Severance is subject to administration, including curtailment, by the State Engineer's Office.
18. Acknowledgements. It is expressly understood that Thornton and Severance cannot be legally bound by the representations of any of its officers or agents or their designees except in accordance with the Thornton City Charter and Thornton City Code, the Severance Home Rule Charter and Severance Municipal Code, and the laws of the State of Colorado. Nothing contained in this Agreement shall constitute or be interpreted as a repeal of existing codes or ordinances, or as a waiver or abrogation of each other's legislative, governmental, or police powers to promote and protect the health, safety and general welfare of their respective city and town or its inhabitants; nor shall this Agreement prohibit the enactment by Thornton or Severance within their respective jurisdictions of any fee, ordinance, resolution, rule or regulation which is of uniform and general application.
19. Notice. All notices required under this Agreement shall be in writing, except for notices regarding activation of the Interconnect provided in paragraph 7 above and shall be hand-delivered or sent by registered or certified mail, return receipt requested, postage prepaid, to the addresses of the Parties herein set forth. All notices so given shall be considered effective on the date of delivery or seventy-two (72) hours after deposit in the United States mail with the proper address as set forth below. Party by notice so given may change the address to which further notices shall be sent.

Notice to Town: Town Manager
Town of Severance
3 South Timber Ridge Pkwy
PO Box 339
Severance, Colorado 80546

with copy to: Town Attorney
Town of Severance
3 South Timber Ridge Pkwy
PO Box 339
Severance, Colorado 80546

Notice to Property Owner: City of Thornton
Assistant City Manager of Infrastructure
9500 Civic Center Drive
Thornton, CO 80229

with a copy to: City Attorney
City of Thornton
9500 Civic Center Drive
Thornton, CO 80229

Notwithstanding the foregoing, either Party may provide electronic mail ("e-mail") notice on the condition that the other Party acknowledges receipt of the e-mail and does not object to the delivery of notice by e-mail.

20. Assignment. Thornton shall have the right to assign or transfer all or any of its interests, rights, or obligations under this Agreement related to the Pipeline to any person or entity, directly or indirectly, controlling, controlled by, or under common control with Thornton without the consent of Severance. The terms "controlling," "controlled by," or "under common control with," shall mean the possession, direct or indirect, of the power to direct or cause the direction of the management and policies of an entity whether through the ownership of voting securities or otherwise. Thornton shall also have the right to assign or transfer all or any of its interests, rights, or obligations under this Agreement related to the Pipeline to any other person or entity having the legal authority and financial ability to perform the obligations being assigned to such person or entity after at least thirty (30) days prior written notice to Severance and obtaining Severance's consent, which shall not be unreasonably withheld. Upon such notice and written assumption of the obligations of Thornton by an assignee, the assignor shall be relieved of any further obligations or liability with respect to the performance of any of the duties or obligations of Thornton which have been assigned or transferred arising after the date such duties and obligations are assumed by the assignee. Severance may not assign its rights hereunder without first obtaining Thornton's approval in writing.

21. Authority to execute documents. This Agreement must be mutually approved by Thornton's City Council and Severance's Town Council. Thornton City Council's approval of this Agreement will authorize the Thornton City Manager to execute this Agreement, the SOP and other documents as needed as long as the documents are consistent with the terms of this Agreement. Severance's Town Council's approval of this Agreement will authorize the Severance Town Manager or his or her designee to execute all documents necessary to allow for operation and maintenance of the Interconnect in Severance, including, but not limited to the SOP, all easements, permits and licenses, as long as the documents are consistent with the terms of this Agreement.
22. Title and authority. The persons signing this Agreement on behalf of Thornton and Severance represent and warrant that he or she has full power and authority to enter into this Agreement on behalf of Thornton or Severance, respectively. Severance and Thornton understand that each is relying on such representations and warranties in entering into this Agreement.
23. Colorado Governmental Immunity Act. The Parties hereto understand and agree that they are relying on, and do not waive or intend to waive, by any provision of this Agreement, any rights, protections, or privileges provided by the Colorado Governmental Immunity Act, C.R.S. 24-10-101 et seq., as it is from time to time amended, or otherwise available to the Parties, their officers, or employees.
24. Entire agreement - amendments. This Agreement represents the entire agreement of the Parties with respect to the installation and operation of the Interconnect. There are no promises, terms, conditions, or obligations other than those contained herein, which shall supersede all previous communications, representations or agreements, either verbal or written, between the Parties hereto. This Agreement may be amended only by written agreement between Thornton and Severance.
25. Severability. If any part, term, or provision of any portion of this Agreement is held by a court of competent jurisdiction to be illegal, unenforceable, declared void or in conflict with any law of the State of Colorado by final court action, meaning that no appeal can be made or the time to appeal has expired, the validity of the remaining portions or provisions shall not be affected, and the rights and obligations of the Parties shall be construed and enforced as if the Agreement did not contain the particular part, term, or provision held to be invalid, and the Parties shall cooperate to cure any such defect. If such defect has affected the ability of Thornton to install, construct or maintain the Interconnect in Severance after cure, the Parties agree to take such reasonable steps as are necessary to allow installation, construction, maintenance and operation of the Interconnect.
26. Effective date. This Agreement shall be effective and binding upon both Parties as of the date first set forth above.
27. Further assurances. The Parties agree to execute such additional documents and take such additional action as may be necessary to effectuate the intent of this Agreement.

28. No duress. The Parties agree that this Agreement is freely and voluntarily executed by them after an opportunity for each party to obtain legal advice.
29. Execution and counterparts. This Agreement may be executed and filed in any number of counterparts, all of which when taken together shall constitute the entire agreement of the Parties. Signature pages may be removed from any counterpart and attached to another counterpart to constitute a single document.
30. Governing law. This Agreement shall be governed by and construed in accordance with the laws of the State of Colorado. Should any party institute legal suit or action for enforcement of any right or obligation contained herein, it is agreed that exclusive venue of such suit or action shall be in Weld County, Colorado.
31. Third party beneficiaries. This Agreement is made by and between the Parties and, to the extent permitted, successors or assigns and solely for their benefit. No third parties shall be entitled to enforce the duties or enjoy the rights created herein.
32. Captions. The captions to this Agreement are inserted only for the purpose of convenient reference and in no way define, limit or prescribe the scope or intent of this Agreement or any part thereof.
33. Approvals. Whenever approval or acceptance of Severance is necessary pursuant to any such request for provisions of this Agreement, Severance shall act in a timely manner in responding to approval or acceptance and shall not unreasonably withhold such approval or acceptance.

IN WITNESS WHEREOF, this Agreement has been executed by the Parties, intending to be legally bound hereby as of the date first set forth above.

Exhibits to Agreement

- A – Interconnect Detail
- B – Map for Location of Interconnect

[Signature pages follow]

TOWN OF SEVERANCE, COLORADO,
a Colorado home rule municipality

Matthew Fries, Mayor

ATTEST:

Sarah Jacobsen, Town Clerk

APPROVED AS TO FORM

Andrew Rogers, Town Attorney

STATE OF COLORADO)
) ss.
COUNTY OF WELD)

Signed before me this ____ day of _____ 2026, by Matthew Fries, Mayor, Town of Severance, a Colorado home rule municipality.

WITNESS my hand and official seal.

My commission expires: _____

NOTARY PUBLIC

CITY OF THORNTON, COLORADO,
a Colorado home rule municipality

Tansy Hayward, City Manager

ATTEST:

Kristen N. Long, City Clerk

APPROVED AS TO FORM:

Tami Yellico, City Attorney

STATE OF COLORADO)
) ss.
COUNTY OF ADAMS)

Subscribed and acknowledged before me this ____ day of _____, 2026,
by Tansy Hayward, City Manager, City of Thornton, a Colorado home rule municipality.

WITNESS my hand and official seal.

My commission expires: _____

NOTARY PUBLIC

Exhibit A to INTERGOVERNMENTAL AGREEMENT
BETWEEN THE TOWN OF SEVERANCE,
COLORADO AND THE CITY OF THORNTON,
COLORADO FOR AN EMERGENCY RAW WATER
INTERCONNECTION

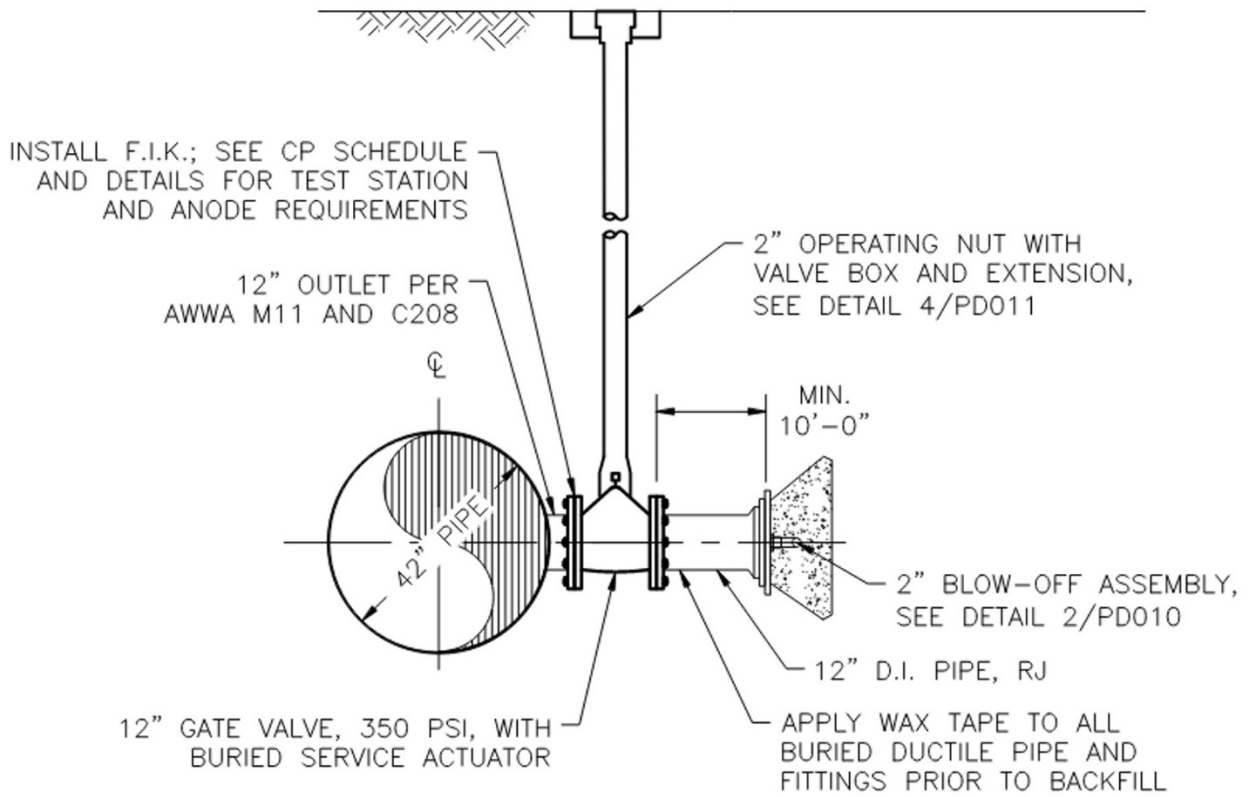

SERVICE VALVE TABLE		
NUMBER	STATION	FLANGE CLASS
	117+80	FLANGE CLASS E/ ANSI B16.1 Cl. 125 B16.5 Cl. 150

12" SERVICE OUTLET
NOT TO SCALE

**Exhibit B to INTERGOVERNMENTAL AGREEMENT
BETWEEN THE TOWN OF SEVERANCE,
COLORADO AND THE CITY OF THORNTON,
COLORADO FOR AN EMERGENCY RAW WATER
INTERCONNECTION**

4604254 07/01/2020 09:34 AM
Page 10 of 10

